

Xmatic

Instruction Manual

Original Instructions



CE

Doc. no.: 16897025_A_en
Date of release: 2022.07.08

Copyright

The contents of this manual are the property of Struers ApS. Reproduction of any part of this manual without the written permission of Struers ApS is not allowed.

All rights reserved. © Struers ApS 2022.10.06.

Table of Contents

1 About this manual	6
1.1 Accessories and consumables	6
2 Safety	6
2.1 Intended use	6
2.2 Safety functions	7
2.2.1 Xmatic safety precautions	8
2.3 Safety messages	9
2.4 Safety messages in this manual	10
3 Getting started	12
3.1 Device description	12
3.2 Overview	14
3.3 The display	16
4 Installation	17
4.1 Unpacking	17
4.2 Lifting	18
4.3 Checking the packing list	22
4.4 Power supply	23
4.5 Noise	25
4.6 Vibration	25
4.7 Compressed air supply	26
4.8 Connecting to the water inlet and outlet	26
4.9 Connecting to an exhaust system	28
4.10 Installing a beacon on the machine	29
4.11 Connecting the recirculation unit	30
4.11.1 Filling the recirculation tank	30
4.11.2 Connecting the recirculation unit to the machine	31
4.12 Adjusting disc cooling and OP-flushing	32
4.13 Mounting the MD-Disc	33
5 Transport and storage	34
5.1 Storage	34
5.2 Transport	34
6 Start-up - the first time	36
6.1 Mounting the grinding stone or diamond grinding disc	36
6.2 MD surfaces	38

6.3	Bottle rack	40
6.3.1	Placing bottles in the bottle rack module	40
6.3.2	Soap and alcohol	41
7	Configuration	41
7.1	Preparation	42
7.1.1	Manual dressing	44
7.2	Machine settings	45
7.3	Cleaning templates	47
7.3.1	Creating cleaning templates	48
8	Operating the device	49
8.1	Clamping and leveling specimens	50
8.2	Placing and removing the specimen holder in/from the vertical conveyor	50
8.3	Methods	52
8.3.1	Struers methods	52
8.3.2	Custom methods	53
8.4	The preparation process	56
8.4.1	Consumables	57
8.4.2	Starting the preparation process	57
9	Maintenance and service - Xmatic	58
9.1	General cleaning	58
9.2	When necessary	58
9.2.1	Air filter	58
9.2.2	Cleaning the MD-Disc	59
9.2.3	Cleaning the grinding stone station	61
9.2.4	Cleaning the tubes	62
9.2.5	Replacing the stone dresser and the MD dressers	65
9.2.6	Cleaning the touch screen	65
9.2.7	Cleaning the MD elevator mirrors	66
9.2.8	Emptying the alcohol separator bottle - (Optional)	66
9.2.9	MD dressers	68
9.3	Daily	68
9.3.1	MD grinding surfaces	68
9.4	Weekly	69
9.4.1	The machine	69
9.4.2	High pressure cleaning station	72
9.4.3	Ultrasonic cleaning station - (Optional)	73
9.5	Monthly	74
9.5.1	Recirculation unit	74
9.6	Annually	75

9.6.1 Main safety cover	76
9.6.2 Testing safety devices	76
9.7 Spare parts	78
9.8 Service and repair	78
9.9 Disposal	78
9.9.1 Environmental considerations	78
10 Troubleshooting - Xmatic	79
10.1 Accessing the work zone in case of power failure	79
11 Technical data	81
11.1 Technical data	81
11.2 Safety Related Parts of the Control System (SRP/CS)	86
11.3 Diagrams	87
11.3.1 Diagrams - Xmatic	88
11.4 Legal and regulatory information	92
12 Manufacturer	92
Declaration of Conformity	93

1 About this manual

Instruction Manuals

Struers equipment must only be used in connection with and as described in the Instruction Manual supplied with the equipment.



Note

Read the instruction manual carefully before use.



Note

If you wish to view specific information in detail, see the online version of this manual.

1.1 Accessories and consumables

Accessories

For information about the available range, see: [The Struers Website](http://www.struers.com) (<http://www.struers.com>).

Consumables

The equipment is designed to be used only with Struers consumables specifically designed for this purpose and this type of machine.

Other products may contain aggressive solvents, which dissolve e.g. rubber seals. The warranty may not cover damaged machine parts (e.g. seals and tubes), where the damage can be directly related to the use of consumables not supplied by Struers.

For information about the available range, see:

- [The Struers Consumables Catalogue](http://www.struers.com/Library) (<http://www.struers.com/Library>)

2 Safety

2.1 Intended use

For professional automatic materialographic grinding and polishing of materials for further materialographic preparation. The machine is only to be operated by skilled/trained personnel. The machine is designed to be used with Struers consumables specially designed for this purpose and this type of machine.

The machine is for use in a professional working environment (e.g. a materialographic laboratory).

Do not use the machine for the following	Preparation of materials other than materials suitable for materialographic studies. The machine must not be used for any type of explosive and/or flammable material, or materials which are not stable during machining, heating or pressure.
Model	Xmatic with high-pressure cleaning Xmatic with high-pressure cleaning and ultra-sonic cleaning

2.2 Safety functions

The machine is equipped with the following safety devices:

- Emergency stops
Stops all hazardous movements
- Plane grinding guard interlock (abrasive guard)
Prevents the stone/disc from turning when the lid is open
- Limited speed function, plane grinding station
Stops the motor if the rotational speed is exceeded
- Limited speed function, specimen mover head
Stops the motor if the rotational speed is exceeded
- Main safety cover interlock, hazardous movements
Prevents any movement in the work zone when the main safety cover is open
- Main safety cover interlock, water and ethanol
Prevents water and ethanol from being dosed when the main safety cover is open
- Main safety cover interlock with locking function
Prevents access to any moving part in case of after-run or loss of power
- MD elevator door interlock
Prevents the elevator from moving when the door is open
- MD elevator door interlock with locking function
Prevents access to the MD elevator in case of after-run or loss of power
- Vertical conveyor doors interlock
Prevents movements in the vertical conveyor when the door is open
- Recirculation unit doors interlocks
Prevents the pumps from operating when the door is open
- Exhaust supervision system
Prevents the use of ethanol in case there is no exhaust system mounted

Emergency stops

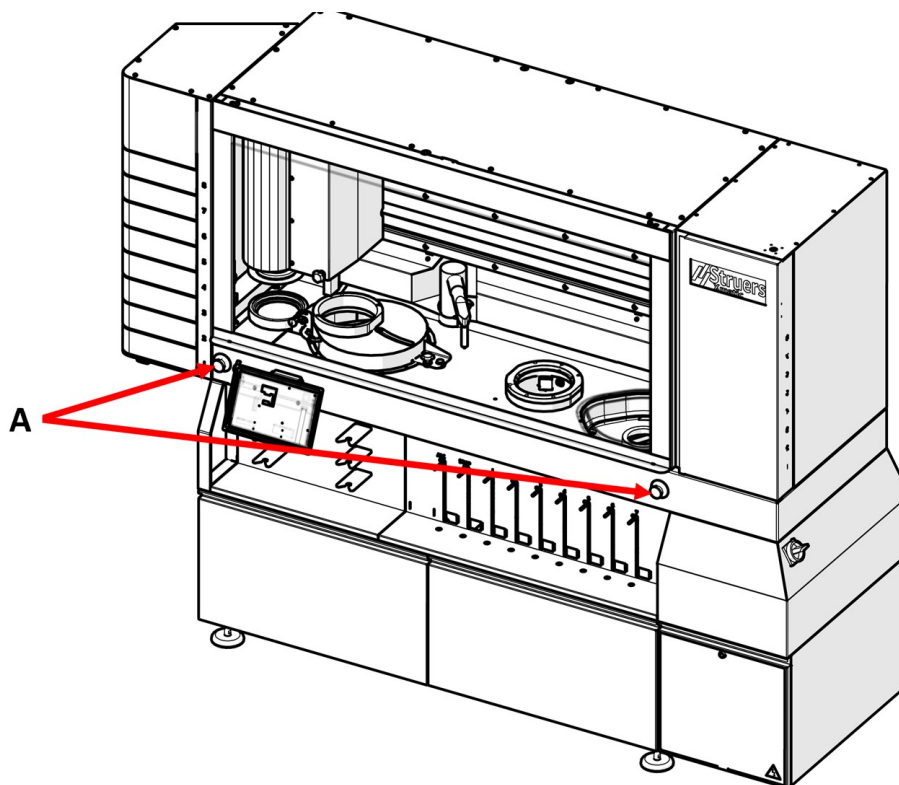

A Emergency stops

Accessing the preparation area during preparation

Once the machine has completed the preparation, you must wait approximately 3 minutes before you can open the main safety cover.

2.2.1 Xmatic safety precautions



Read carefully before use

Specific safety precautions - residual risks

1. Ignoring this information and mishandling of the equipment can lead to severe bodily injuries and material damage.
2. Make sure that the actual electrical power supply voltage corresponds to the voltage stated on the type plate of the machine. The machine must be earthed (grounded).
3. Switch off the machine, disconnect the electrical power cable before you dismantle the machine or install additional components.
4. Connect the machine to a cold water tap. Make sure that the water connections are leak-proof and that the water outlet is working. Cut off the water supply if the machine is not going to be used for a long period of time.
5. Make sure that the emergency stop is in working order.

6. When using specimen holders, make sure that all specimens are securely clamped and properly balanced before you start the preparation process.
7. Wear suitable gloves to protect fingers from abrasives and warm/sharp specimens.
8. The equipment is designed to be used only with Struers consumables specifically designed for this purpose and this type of machine.

General safety precautions

1. The machine must be installed in compliance with local safety regulations. All functions on the machine and any connected equipment must be in working order.
2. The operator must read the safety precautions and Instruction Manual, as well as relevant sections of the manuals for any connected equipment and accessories.
The operator must read the Instruction Manual and, where applicable, the Safety Data Sheets for the applied consumables.
3. Struers equipment must only be used in connection with and as described in the Instruction Manual supplied with the equipment.
4. Dismantling of any part of the equipment, during service or repair, should always be performed by a qualified technician (electromechanical, electronic, mechanical, pneumatic, etc.).
5. If you observe malfunctions or hear unusual noises, switch off the machine and call technical service.
6. If the equipment is subjected to misuse, incorrect installation, alteration, neglect, accident or incorrect repair, Struers will accept no responsibility for damage to the user or the equipment.

2.3 Safety messages

Struers uses the following signs to indicate potential hazards.



ELECTRICAL HAZARD

This sign indicates an electrical hazard which, if not avoided, will result in death or serious injury.



DANGER

This sign indicates a hazard with a high level of risk which, if not avoided, will result in death or serious injury.



WARNING

This sign indicates a hazard with a medium level of risk which, if not avoided, could result in death or serious injury.



CAUTION

This sign indicates a hazard with a low level of risk which, if not avoided, could result in minor or moderate injury.



CRUSHING HAZARD

This sign indicates a crushing hazard which, if not avoided, could result in minor, moderate or serious injury.



HEAT HAZARD

This sign indicates a heat hazard which, if not avoided, can result in minor, moderate or serious injury.

General messages



Note

This sign indicates that there is a risk of damage to property, or a need to proceed with special care.



Hint

This sign indicates that additional information and hints are available.

2.4 Safety messages in this manual



WARNING

If there are visible signs of deterioration or damage to the main safety cover, it must be replaced immediately.
Contact Struers Service.



WARNING

Safety critical components must be replaced after a maximum lifetime of 20 years.
Contact Struers Service.



WARNING

Do not use the machine with defective safety devices.
Contact Struers Service.



WARNING

In case of fire, alert bystanders and the fire brigade. Turn off the power. Use a powder fire extinguisher. Do not use water.



ELECTRICAL HAZARD

The machine must be earthed (grounded).
Make sure that the actual electrical power supply voltage corresponds to the voltage stated on the type plate of the machine.
Incorrect voltage can damage the electrical circuit.



ELECTRICAL HAZARD

The equipment is protected by a safety insulation transformer.
Make sure that the adequate ik_min level is present.
Contact a qualified electrician to verify the solution.
Always follow local regulations.

**ELECTRICAL HAZARD**

Disconnect the electrical power supply before installing electrical equipment. Make sure that the actual electrical power supply voltage corresponds to the voltage stated on the type plate of the machine. Incorrect voltage can damage the electrical circuit.

**ELECTRICAL HAZARD**

The pump of the recirculation cooling unit must be earthed (grounded). Make sure that the electrical power supply voltage corresponds to the voltage stated on the type plate of the pump. Incorrect voltage can damage the electrical circuit.

**ELECTRICAL HAZARD**

Disconnecting the unit from the electrical power supply must only be done by a qualified technician.

**CAUTION**

Struers equipment must only be used in connection with and as described in the Instruction Manual supplied with the equipment.

**CAUTION**

Do not use the machine if it is damaged.

**CAUTION**

The safety devices must be tested at least once a year.

**CAUTION**

Testing should always be performed by a qualified technician (electromechanical, electronic, mechanical, pneumatic, etc.).

**CAUTION**

Prolonged exposure to loud noises may cause permanent damage to a person's hearing. Use hearing protection if the exposure to noise exceeds the levels set by local regulations.

**CAUTION**

Do not use the machine with non-compatible accessories or consumables.

**CAUTION**

Wear suitable gloves to protect fingers from abrasives and warm/sharp specimens.

**CAUTION**

Make sure that the machine is level.



CAUTION

The machine must not operate when it is resting on its wheels.



CAUTION

Avoid skin contact with the cooling fluid additive.



CAUTION

The recirculation tank is very heavy when it is full.



CAUTION

The pressure of the cooling fluid supplied to the machine must be max. 2 bar.

3 Getting started

3.1 Device description

The machine is an automatic machine for materialographic grinding, polishing and cleaning.

The operator selects the preparation parameters, the grinding/polishing surfaces, and suspension/lubricant to be used for the method. There are standard preparation and cleaning methods on the machine, and customized methods can be added.

The operator starts the process by placing a specimen holder in a drawer on the vertical conveyor. Up to 8 specimen holders can be placed in the vertical conveyor.

When a specimen holder is placed in the vertical conveyor, the machine automatically detects the specimen holder and indicates it on the graphical user interface (GUI). The surface area of the specimens to be prepared can automatically be identified by the machine to determine parameters: force, water flow and correct dosing levels of suspension/lubricant.

The operator selects between different grinding/polishing methods and/or cleaning methods for each individual specimen holder.

The operator presses “start” to initiate the process based on the methods selected for each specimen holder. The vertical conveyor delivers the specimen holder to the pick-up point from where the mover head picks it up. Depending on the selected method, the mover head brings the specimen holder through each of the process steps.

A typical method includes a high removal plane grinding step, followed by a cleaning step in the ultrasonic chamber, or the high-pressure cleaning chamber. Afterwards, a series of grinding and or polishing steps are carried out on the MD grinding/polishing station. In the MD station, the machine can automatically exchange the MD surfaces and position the doser arm over the MD surface.

During a step on the MD station the machine automatically doses the selected consumables or water. Between each step on the MD station the specimen holder is typically cleaned and dried.

After the last process step, the mover head delivers the specimen holder back to the pick-up point from where the vertical conveyor brings it back to the drawer. The drawer opens automatically to indicate that the specimens in the specimen holder are ready for inspection.

The machine is able to automatically process all the specimen holders in the vertical conveyor without operator intervention.

The machine recognizes all Struers consumables present in the machine. This allows the machine to prompt the operator about missing or low consumable levels for the selected methods.

The main safety cover of the machine locks when the operator starts the machine, and it remains locked until all hazardous movements are stopped. It is not possible for the machine to run a process while the main safety cover is open.

Cleaning

Cleaning is done via high-pressure cleaning and/or ultrasonic cleaning depending on the selected cleaning method. These types of cleaning are carried out in two separate chambers. Alcohol can be applied during cleaning and drying of water-sensitive materials, and it is a part of the high-pressure cleaning process. Concentrated soap can also be applied during the high-pressure cleaning process.

MD elevator

MD surfaces will automatically be exchanged depending on the selected method. Up to 8 different grinding/polishing surfaces can be placed in the MD elevator.

The operator can access the MD elevator while the machine is preparing a specimen holder, but not while it is changing a grinding/polishing surface.

Bottle rack

Several suspensions and lubricant including oxide polishing suspension can be chosen depending on the method. The bottle rack can fit up to 7 bottles of consumables and 1 for alcohol and 1 for concentrated soap. The consumable bottles are connected to the machine via a connector dedicated for each individual bottle position.

The operator can change a suspension/lubricant bottle while the machine is preparing a specimen holder, however not if it is using the suspension/lubricant in question.

If a bottle is removed and a new is inserted, the GUI will ask if it is necessary to automatically flush, and the tube can be inserted in the flush function before it is attached to the new bottle.

The machine is equipped with 2 emergency stops. If one of the emergency stops is activated, all hazardous moving parts are stopped.

Models

Xmatic with high-pressure cleaning

Xmatic with high-pressure cleaning and ultrasonic cleaning

3.2 Overview

Front view

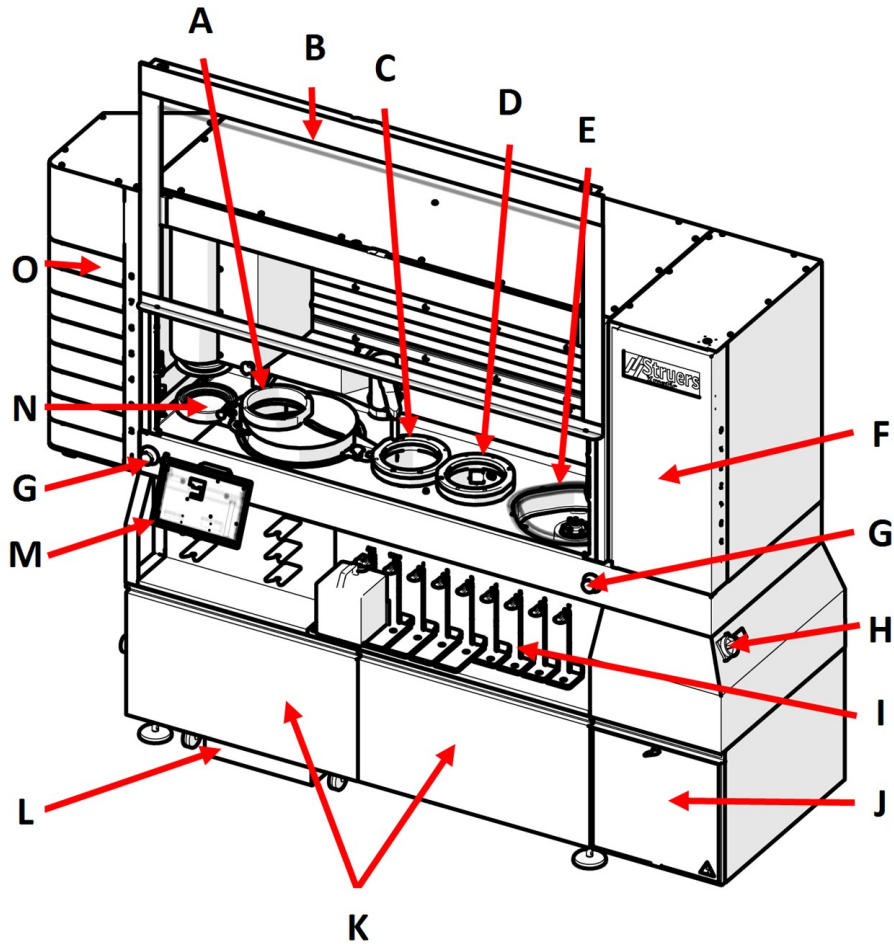

- A Grinding station
- B Main safety cover
- C Ultrasonic cleaning station (Optional)
- D High pressure cleaning station
- E MD grinding and polishing
- F MD elevator
- G Emergency stop
- H Main switch
- I Bottle rack
- J Electrical compartment
- K Recirculation unit compartment
- L Recirculation unit
- M Display
- N Pick-up point
- O Vertical conveyor

Side view

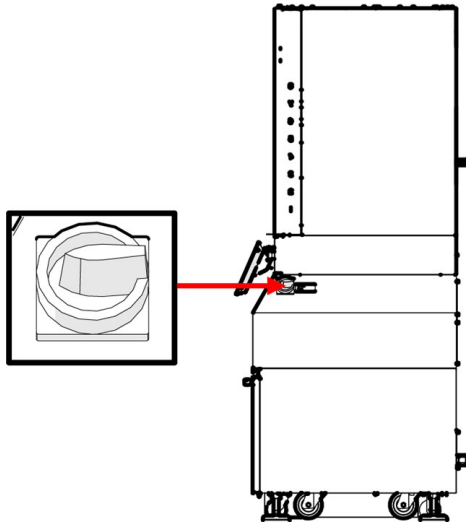

Right side

Main switch.

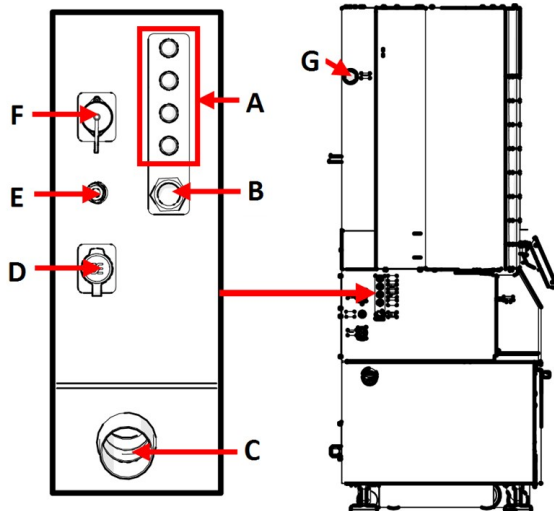

Left side

- A Water flow regulators and water supply
- B Water inlet
- C Water outlet
- D Ethernet connection
- E Compressed air
- F External control signal
- G Exhaust

Rear view - Power supply

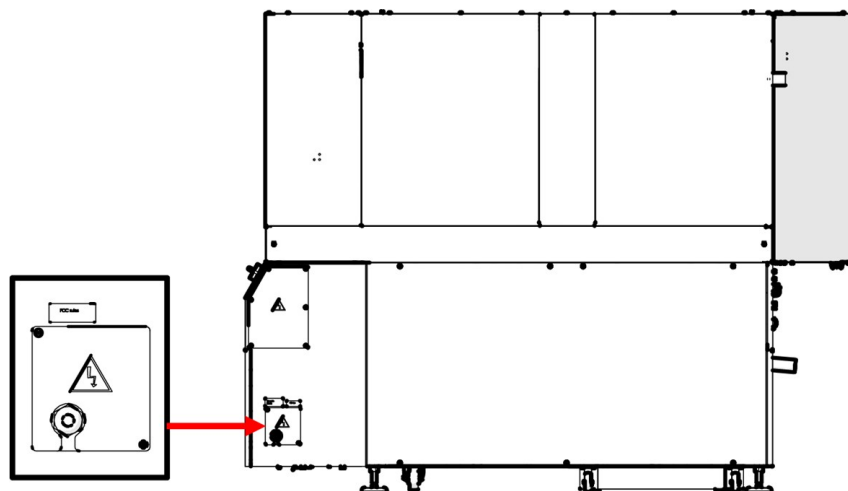

3.3 The display

The display is a touch screen, where you tap on buttons, icons and specific areas to access a screen or activate a function.

All programming and operation is carried out on the touch screen.

The software is launched when you switch on the machine.

Overview

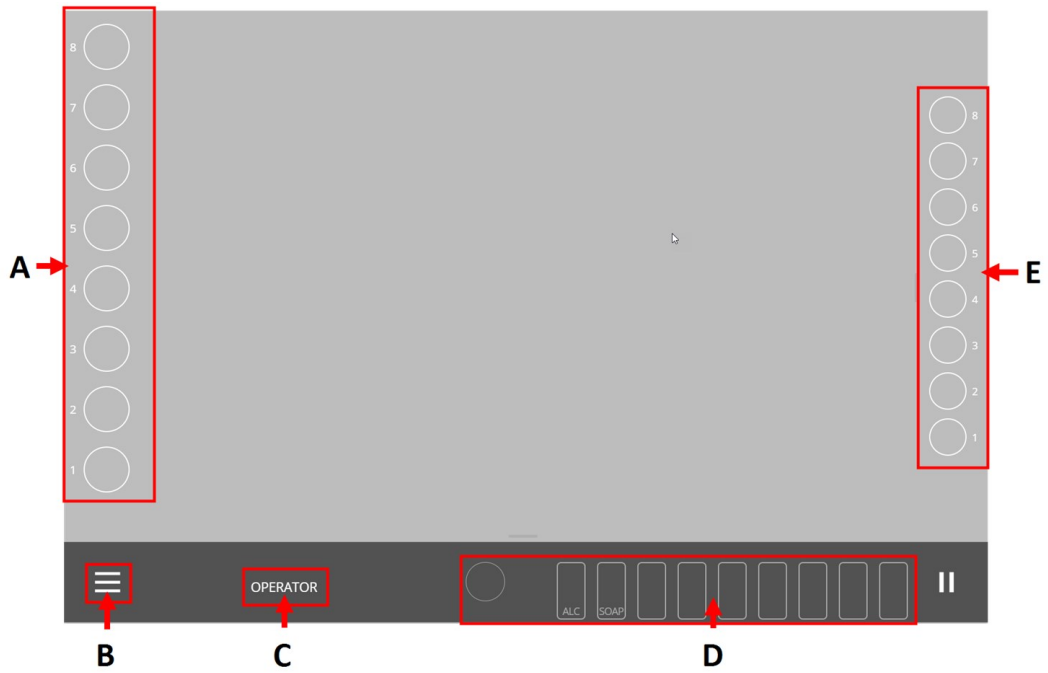

- A Specimen holders ribbon
- B Main menu
- C User modes
- D Consumables ribbon
- E MD surface ribbon

Detailed view

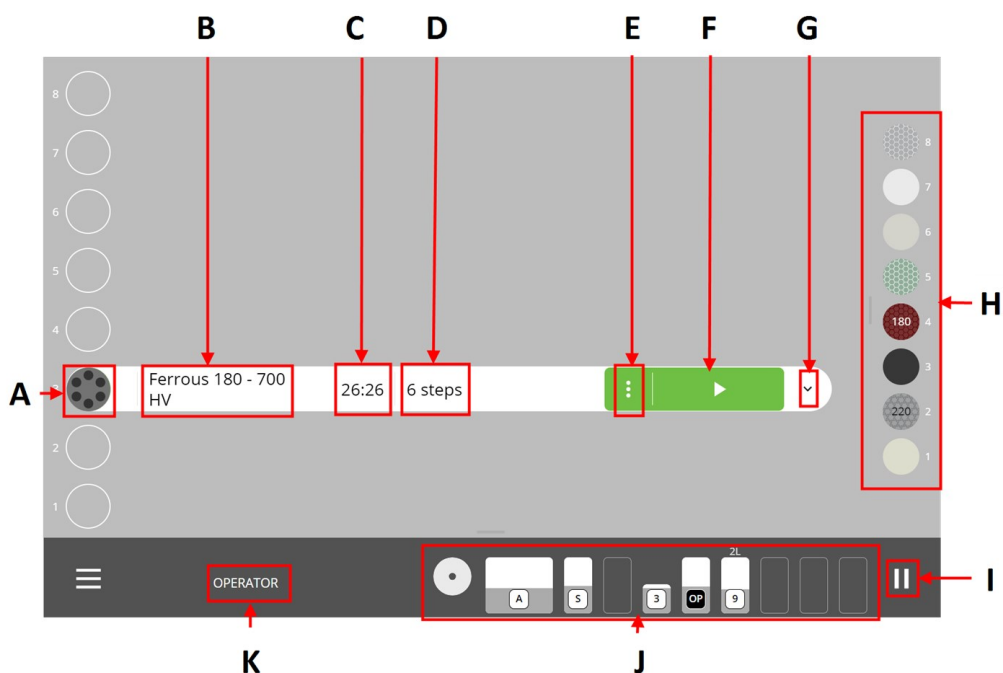

- A** This item indicates that there is a specimen holder in the drawer, and it shows how many specimens it contains.
- B** This item shows the name of the selected method.
- C** This item shows the time it takes to run the selected method.
- D** This item shows the number of steps included in the method.
- E** Tap this item to access the **Step selection** and **Edit method** submenus.
- F** Tap the **Run** button when you are ready to run the selected method. You can also use this button to pause the process while it is running.

**Note**

A green Run button indicates that all the consumables needed for the selected method are in place.
A red Run button indicates that some of the consumables you need to run the method are not in place. Solve the problem before you proceed.

- G** Tap this item to open the drop-down list indicating all the steps for the selected method.
- H** The MD surface ribbon shows which MD surfaces are available in the machine.
- I** Tap the **Pause** button whenever you need to pause the process.
- J** The consumables ribbon shows which consumables are available in the machine.
- K** This item shows the type of user that is logged into the machine.

4 Installation

4.1 Unpacking

The packing box

1. Open and remove the sides and the top of the packing box.

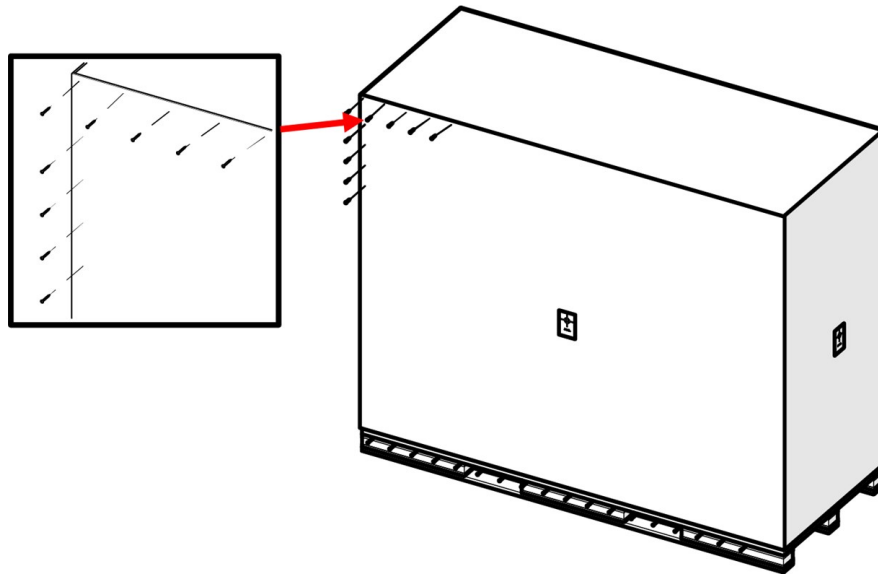

The transport brackets

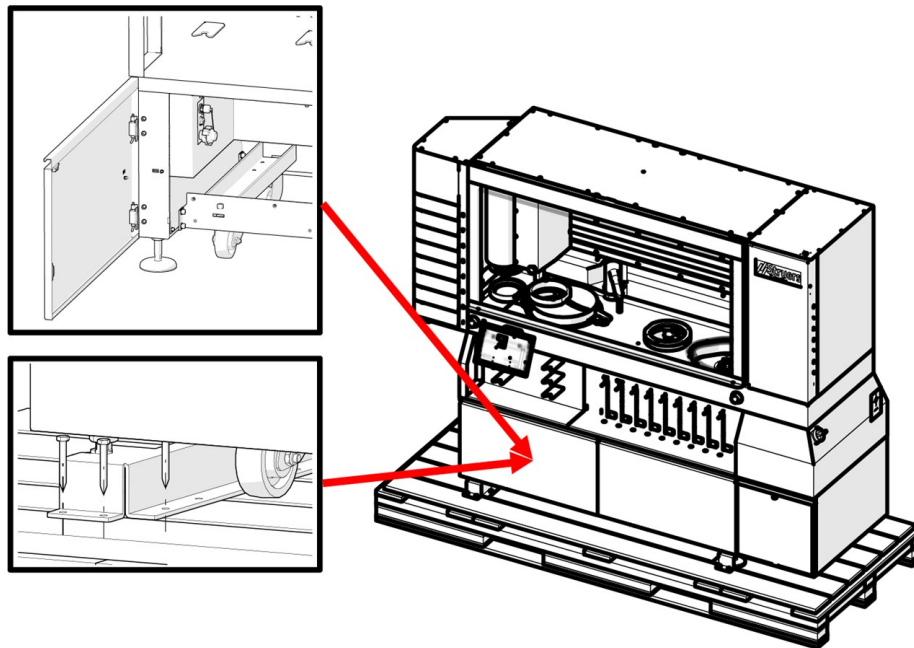

- Unscrew the transport brackets that secure the machine to the pallet.



Note

Struers recommends that all original packaging and fittings are kept for future use.

4.2 Lifting



CRUSHING HAZARD

Take care of your fingers when handling the machine.
Wear safety shoes when handling heavy machinery.

Weight	
Machine	960 kg (2116 lbs)
The weight of the specimen holders and consumables used.	

Center of gravity

Front view

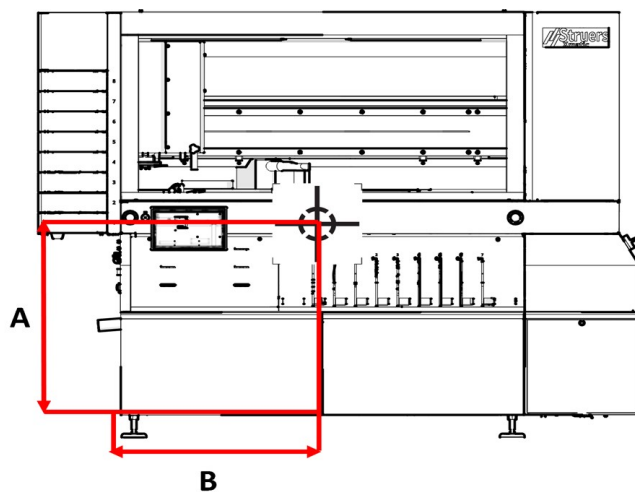

A 884 mm (35")
B 817 mm (32")

Side view

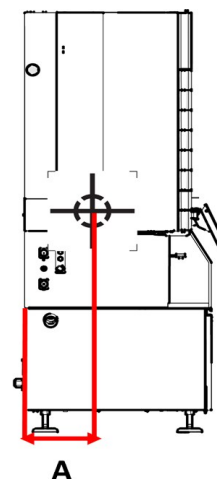

A 329 mm (13")

Lifting the machine from the pallet

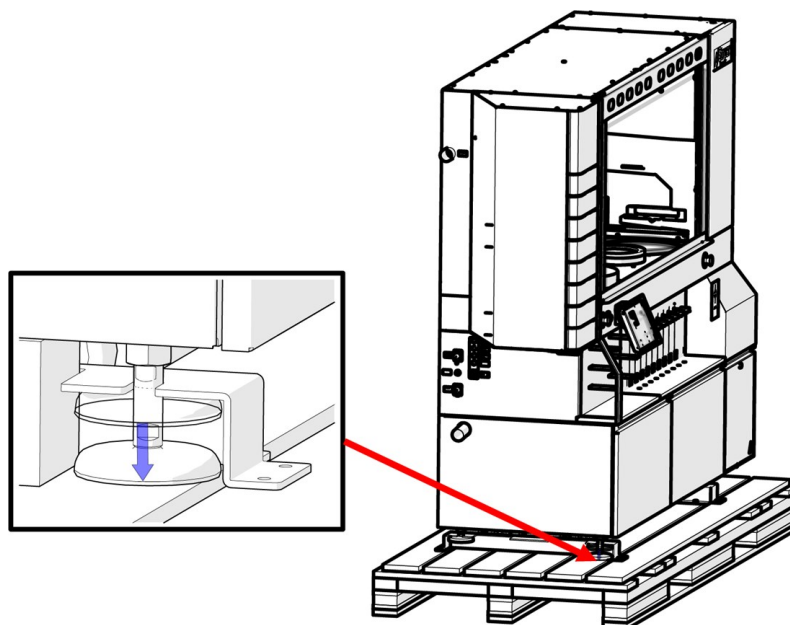

1. Lift the machine from the pallet using a forklift to access the adjustable feet.
2. Loosen the adjustable feet before moving the machine from the pallet. Make sure that the feet are positioned higher than the wheels.

Removing the counterweight screws on the rear side of the machine

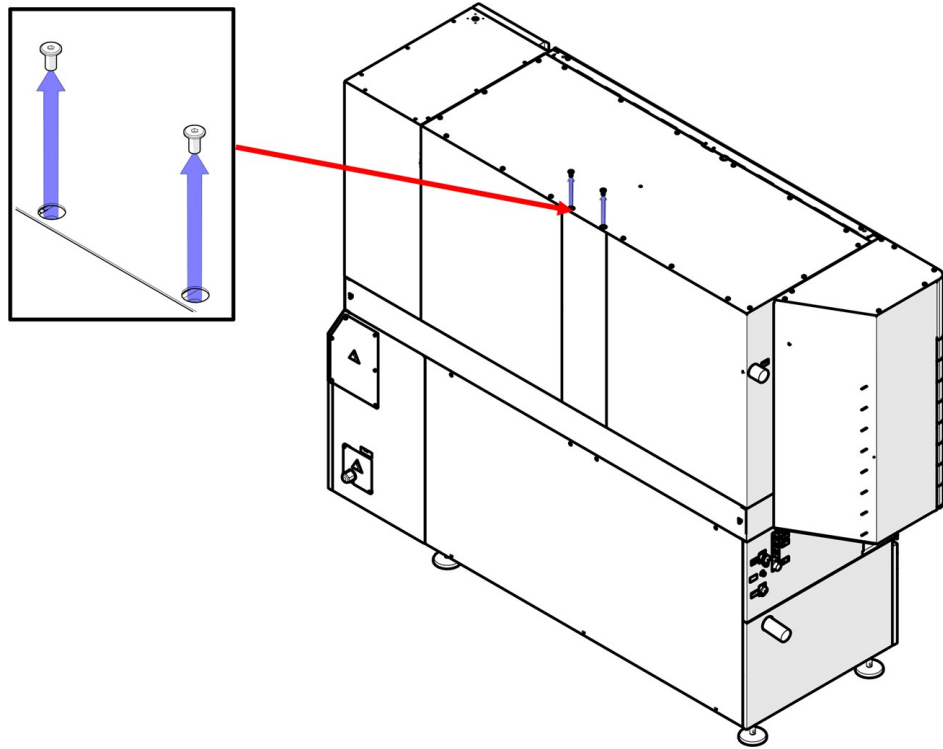

- Use a 5 mm Allen key to remove the counterweight screws.

Moving the machine using a forklift

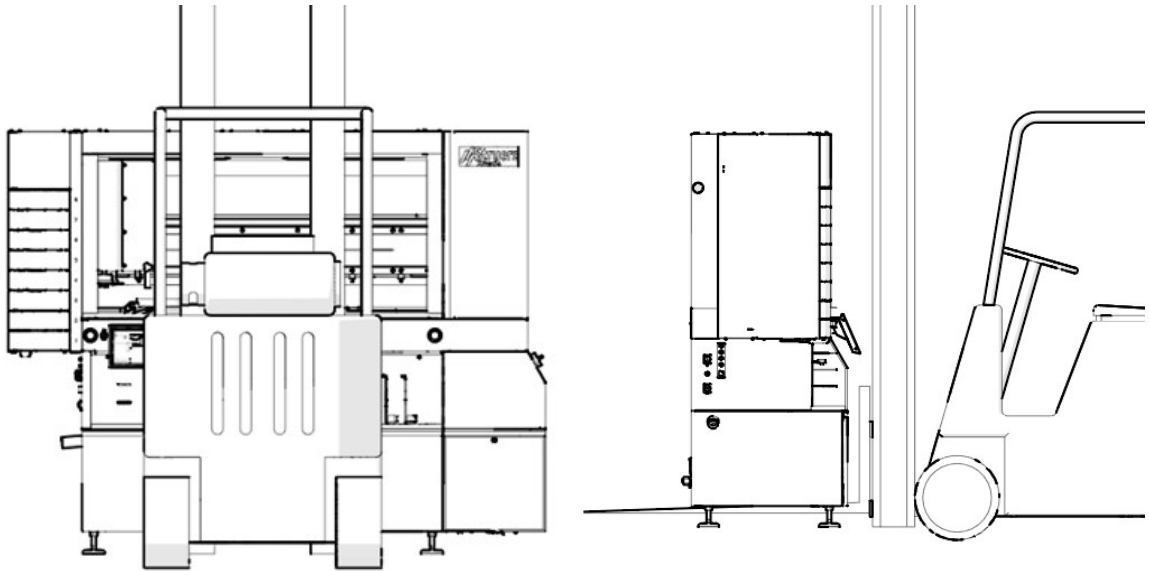

1. Place the forks so that the center of gravity is placed between the forks. Lift the machine from the front.
2. Move the machine into its final position.
3. Lower the machine so that the wheels touch the floor.

**CAUTION**

Make sure that the machine is level.

- Turn the adjustable feet until the machine rests on its feet.

**CAUTION**

The machine must not operate when it is resting on its wheels.

- Remove the transportation crossbar and store it for future use. See also: [Removing the transportation crossbar](#) ► 22

**Note**

Place the machine on a plane and horizontal floor.

Pushing the machine into position

- If you cannot place the machine directly in its location, turn the adjustable feet upwards to stand the machine on its wheels.
- Remove the crossbar and store it for future use. See also: [Removing the transportation crossbar](#) ► 22 The wheels of the machine cannot swivel when the crossbar is mounted.
- Move the machine as close to its position as possible.
- Lower the machine so that the wheels touch the floor.

**Note**

Place the machine on a plane and horizontal floor.

**CAUTION**

The machine must not operate when it is resting on its wheels.

- Push the machine into the correct position.

**CAUTION**

Make sure that the machine is level.

- Turn the adjustable feet until the machine rests on the feet, and make sure that the machine is level.
- Remove the transportation crossbar and store it for future use.

Removing the transportation crossbar

1. Remove the wheels and the transportation crossbar supplied with the machine.
2. Store the crossbar for future use.

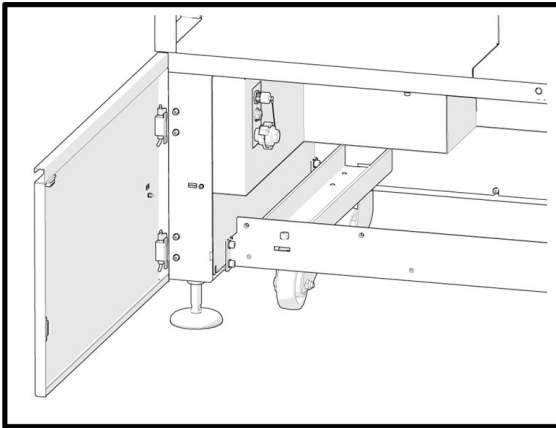

Machine with crossbar

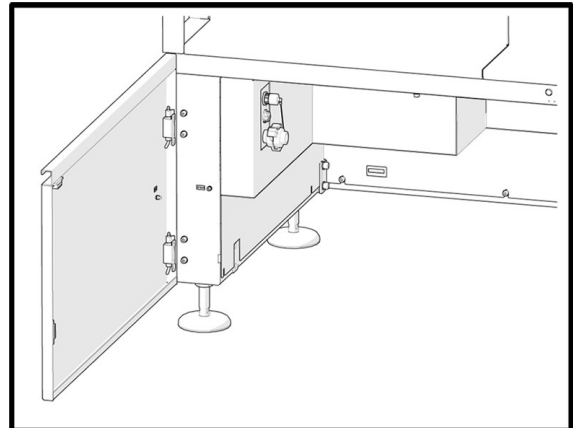

Machine without crossbar

4.3 Checking the packing list

Optional parts can be included in the packing box.

The packing box contains the following items:

Pcs.	Description
1	Xmatic
1	Bottle, square with QR-label, 4 l
4	Bottle placement guides, 1 l
4	Bottle placement guides, 2 l
2	Bottle placement guides, 4 l
1	Triangular key M5, L-200 mm
1	Nozzle cleaning set
1	Recirculation unit, 75 l tank
1	1 filter bag
1	Tube with sleeve, Diameter 50 mm, 320 mm
2	Worm hose clamp, 40-60/9.0-C7W2
1	Tube with sleeve, Diameter 50 mm, 140 mm
1	DBI-DUT100 NA0870A PELD
1	Key Southco E3-26-819-15
1	Water inlet hose, 3/4" connection
2	Hose Danflex K-126, Diameter 51 mm

Pcs.	Description
1	Elbow, 87" 186113 050
1	GEKA blind coupling for tap water inlet

4.4 Power supply



ELECTRICAL HAZARD

The machine must be earthed (grounded).
Make sure that the actual electrical power supply voltage corresponds to the voltage stated on the type plate of the machine.
Incorrect voltage can damage the electrical circuit.



ELECTRICAL HAZARD

The equipment is protected by a safety insulation transformer.
Make sure that the adequate ik_min level is present.
Contact a qualified electrician to verify the solution.
Always follow local regulations.



ELECTRICAL HAZARD

Disconnect the electrical power supply before installing electrical equipment.
Make sure that the actual electrical power supply voltage corresponds to the voltage stated on the type plate of the machine.
Incorrect voltage can damage the electrical circuit.



WARNING

In case of fire, alert bystanders, the fire brigade and cut power. Use a powder fire extinguisher. Do not use water.

Recommended power supply cable specifications

Local standards can override the recommendations for the main electrical power supply cable. If needed, contact a qualified electrician to verify which option is suitable for the local installation setup.

Voltage/frequency: 3 x 200-240 V/50-60 Hz	
Min. fuse: 35 A	Minimum cable size at minimum fuse: 3 x AWG12/2.5 mm ² + PE
Max. fuse: 40 A	Minimum cable size at maximum fuse: 3 x AWG12/2.5 mm ² + PE

Voltage/frequency: 3 x 380-480 V/50-60 Hz	
Min. fuse: 20 A	Minimum cable size at minimum fuse: 3 x AWG14/1.5 mm ² + PE
Max. fuse: 40 A	Minimum cable size at maximum fuse: 3 x AWG12/2.5 mm ² + PE

Electrical data

The other end of the cable can be fitted with an approved plug or hard-wired into the power supply according to the electrical specifications and local regulations.

Voltage/frequency: 3 x 200-240 V/50-60 Hz	
Power consumption	200-240 V: 3.6 kW
Output, main motor	200-240 V: 2.2 kW
Max. load	200-240 V: 15 A

Voltage/frequency: 3 x 380-480 V/50-60 Hz	
Power consumption	380-480 V/50-60 Hz: 3.5 kW
Output, main motor	380-480 V/50-60 Hz: 2.2 kW
Max. load	380-480 V/50-60 Hz: 8 A

Procedure

For specifications see the section Technical data.

The machine is delivered without a power supply cable.

To install the electrical power supply, the following is needed:

- Electrical power supply cable, 4-lead, three phases and one earth connection

1. Connect the cable to the electrical connection box.

PE	Earth (ground)
L1	Phase
L2	Phase
L3	Phase

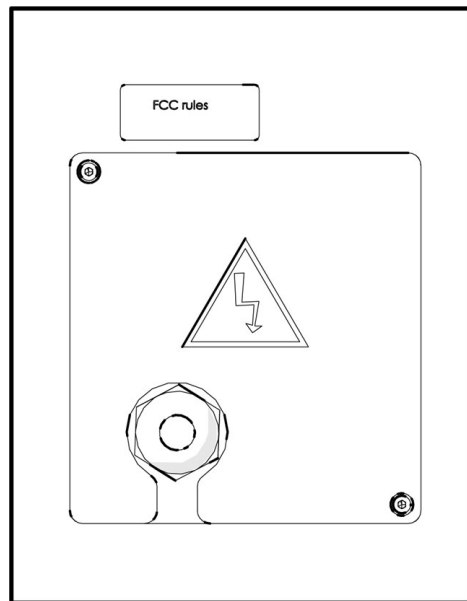

Electrical connection box

EU cable	
L1	Brown
L2	Black

EU cable	
L3	Black or Grey
Earth (ground)	Yellow/Green
Neutral	Blue

UL cable	
L1	Black
L2	Red
L3	Orange/Turquoise
Earth (ground)	Green (or Yellow/Green)
Neutral	White

The other end of the cable can be fitted with an approved plug or hard-wired into the power supply according to the electrical specifications and local regulations.

External short circuit protection

The machine must always be protected by external fuses. See the electrical table for details on the fuse size required.

Residual Current Circuit Breaker (RCCB)



Note

Local standards can override the recommendations for the main electrical power supply cable. If needed, contact a qualified electrician to verify which option is suitable for the local installation setup.

Requirements for electrical installations	
Without Residual Current Circuit Breaker	The equipment must be protected by an insulation transformer (double-wound transformer).

4.5 Noise

For information on the sound pressure level value, see this section: [Technical data ▶ 81](#).



CAUTION

Prolonged exposure to loud noises may cause permanent damage to a person's hearing. Use hearing protection if the exposure to noise exceeds the levels set by local regulations.

4.6 Vibration

For information on the total vibration exposure to hand and arm, see this section: [Technical data ▶ 81](#).

4.7 Compressed air supply

Specifications	
Pressure	6 - 9.9 bar (87 - 143 psi)
Air consumption, approx.	Min. 200 l/min (53 gpm) at atmospheric pressure
Air quality	The air quality is obtained via the internal regulator with built-in filter and water separator.

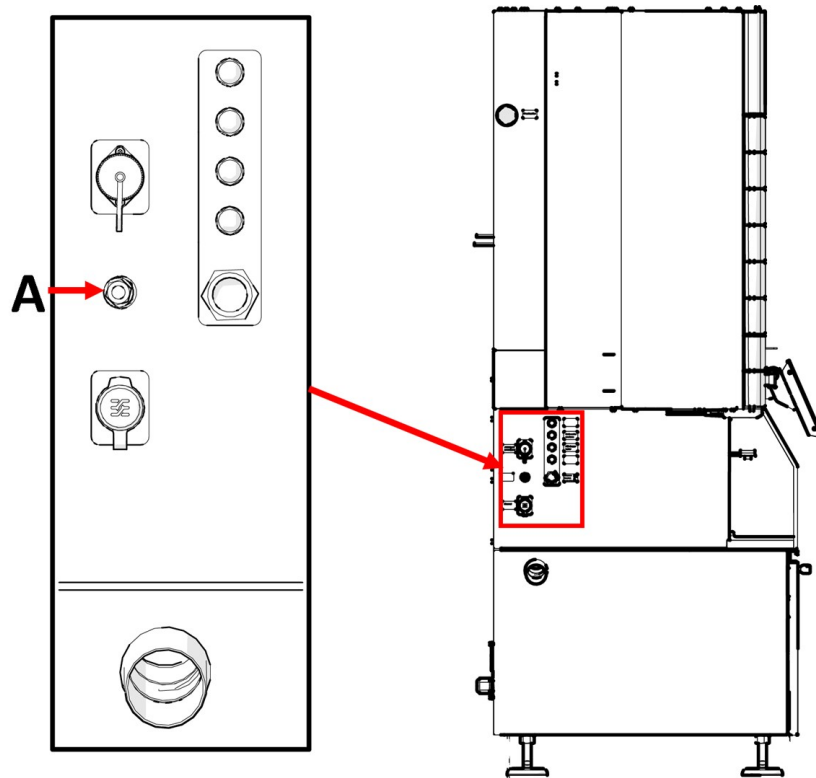

A Compressed air supply

Procedure

1. Connect the compressed 8 mm (5/16") air hose to the compressed air inlet on the machine.
2. Connect the air hose to the compressed air supply.

4.8 Connecting to the water inlet and outlet

Water inlet



Note

New water pipe installations:
Leave the water to run for a few minutes to flush any debris from the pipe before connecting the machine to the water supply.

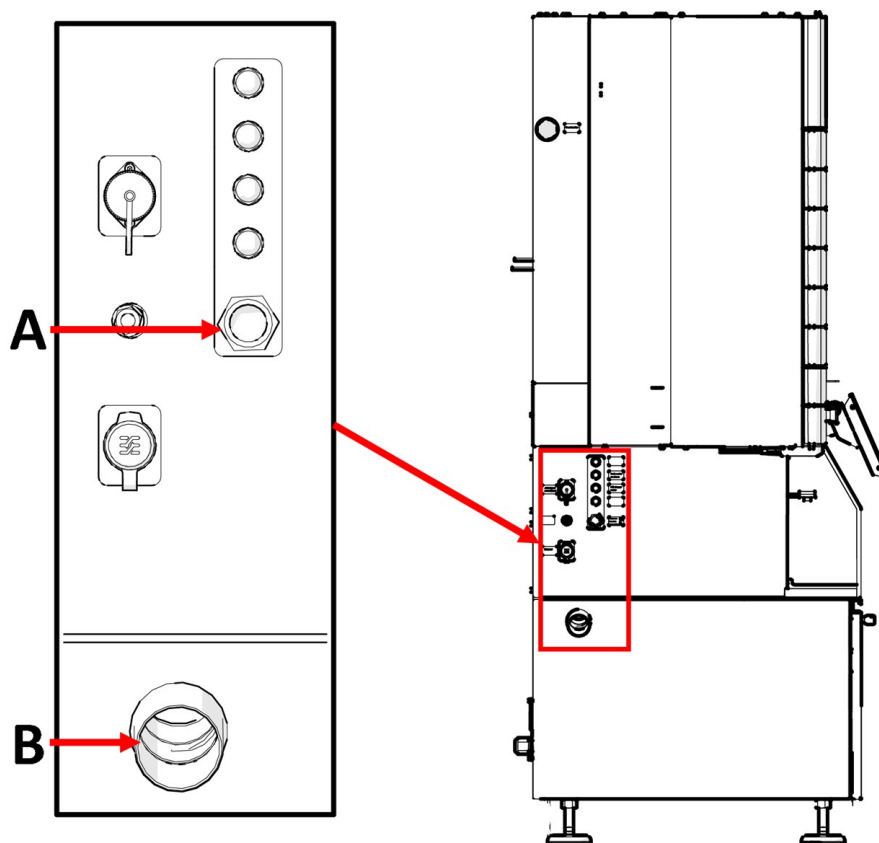

- A** Water inlet
B Water outlet

Procedure

1. Connect one end of the hose to the machine.
2. Connect the opposite end of the hose to the water supply.

The machine is supplied with a standard hose to connect the machine to the water supply.

Water supply - Specifications	
Water pressure	2 - 9.9 bar (29 - 143 psi)
Water flow	Min. 10 l/min. (2.6 gpm)
Connections	Diameter: 3/4". GEKA coupling to recirculation unit.
Tube connection	Reinforced PVC hose

Waste water outlet

Procedure

1. Connect a standard HT water outlet pipe or hose (Diameter: 50 mm (2")) to the water outlet on the left side of the machine.



Note

The distance to the drain must not exceed 6000 mm (236"), and there must be at least 8% slope.



Note

If you are not using a recirculation unit on the grinding stone station, place the GEKA blind coupling on the quick coupling for water connection. See: [Connecting the recirculation unit to the machine](#) ► 31.

4.9 Connecting to an exhaust system



WARNING

An exhaust system with monitoring is required.

Specifications

Minimum capacity: 150 m³/h (5297 ft³/h) at 50 mm (2") diameter.

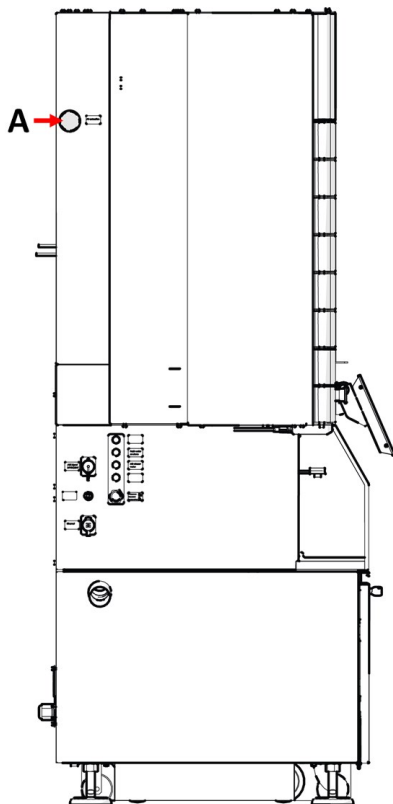

A Exhaust

Procedure

1. Connect a 50 mm (2") pipe to the exhaust outlet on the machine.
2. Connect the other end of the pipe to the exhaust system.

4.10 Installing a beacon on the machine

The machine can be equipped with a beacon.

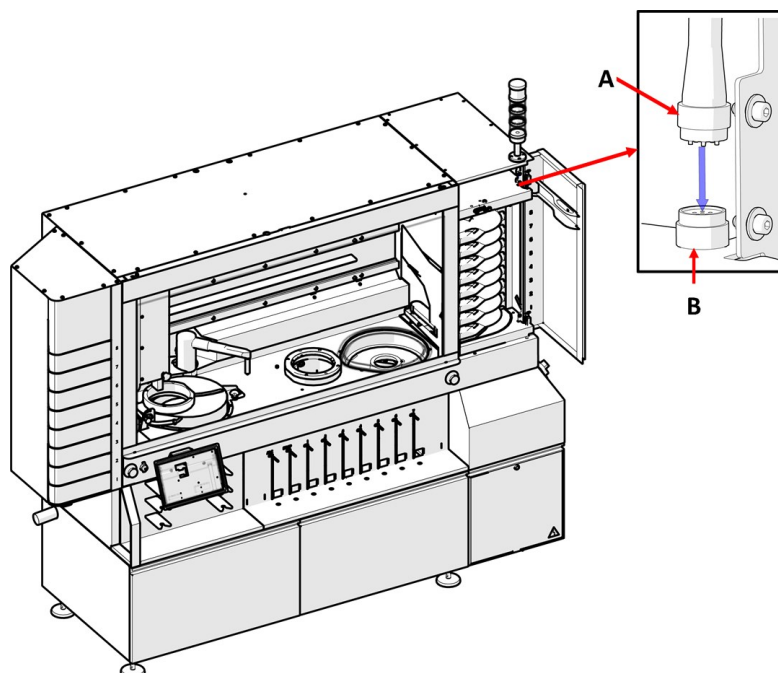
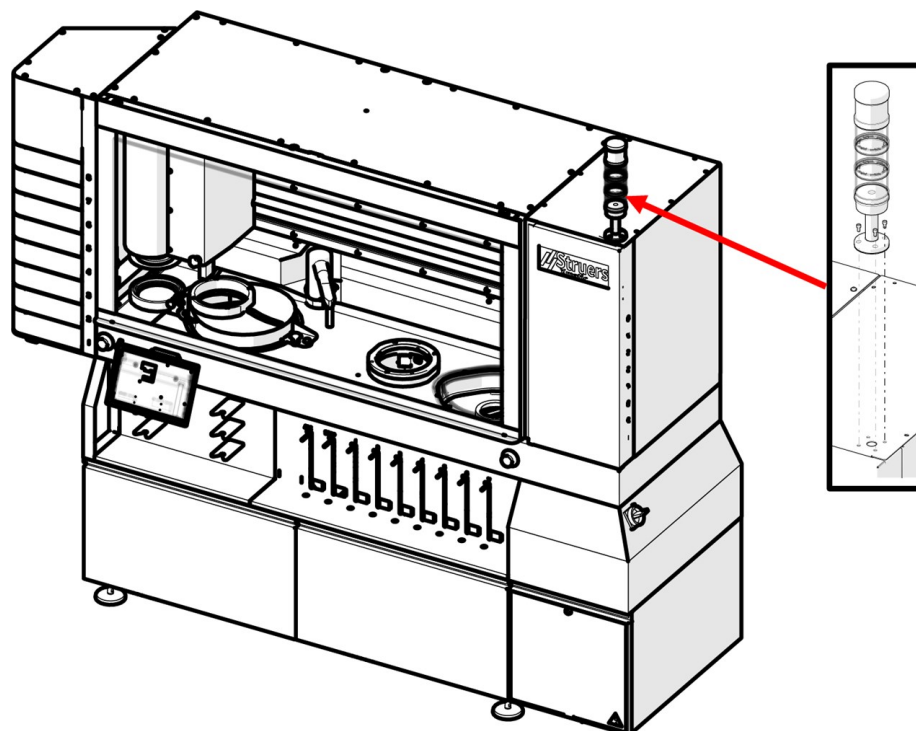

A 6-pole connector

B Socket

1. Open the MD elevator door.
2. Mount the beacon using the socket screws supplied with the beacon.
3. Connect the 6-pole connector to the socket.

4.11 Connecting the recirculation unit

The machine is equipped with a recirculation unit for the plane grinding station. If necessary, it can be equipped with an additional recirculation unit for the MD grinding/polishing station.



ELECTRICAL HAZARD

The pump of the recirculation cooling unit must be earthed (grounded). Make sure that the electrical power supply voltage corresponds to the voltage stated on the type plate of the pump. Incorrect voltage can damage the electrical circuit.



CAUTION

The pressure of the cooling fluid supplied to the machine must be max. 2 bar.

The Struers recirculation unit includes

- a recirculation pump
- a recirculation tank
- a level sensor
- a filter bag for plane grinding
- a GEKA coupling for connection to the machine hose

Consumables

- Struers recommends adding a Struers anti-corrosion additive to the cooling water.
- The use of Struers consumables is recommended.

Other products may contain aggressive solvents, which dissolve e.g. rubber seals. The warranty may not cover damaged machine parts (e.g. seals and tubes), where the damage can be directly related to the use of consumables not supplied by Struers.

4.11.1 Filling the recirculation tank

1. Place a clean plastic liner in the tank.
2. Make sure that the liner lies flat on the base of the tank so that it does not block the pump.
3. The wheels of the unit must be in line with the sides of the compartment so that you can move the unit into position without having to wiggle it from side to side.



CAUTION

The recirculation unit is very heavy when it is full. Place the recirculation unit in its final position, or make sure that you can easily push it into position before filling the tank.



Note

To prevent corrosion, Struers recommends using a Struers additive in the cooling. Remember to top up with Struers additive each time you fill up the tank with water.



Note
Do not overfill the tank.
Avoid spilling when you move the tank.

4.11.2 Connecting the recirculation unit to the machine



Note
See also the Instruction Manual for the recirculation unit.

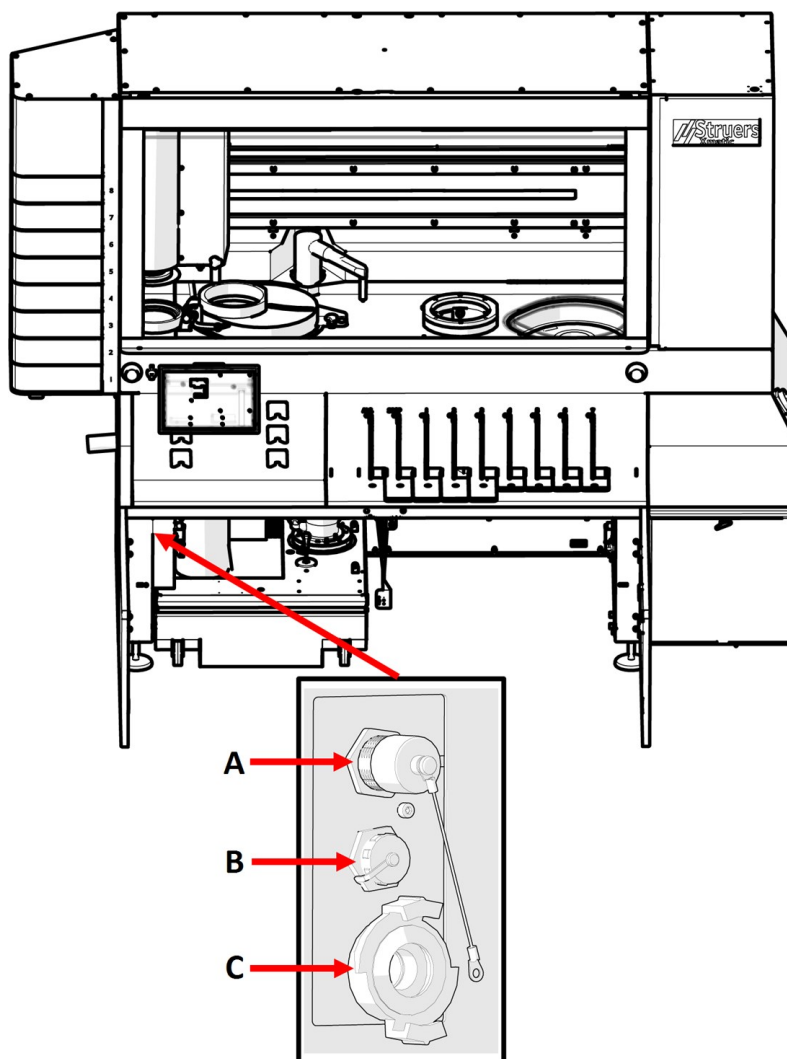

- A Power connector for recirculation unit
- B Power connector for level sensor
- C Quick coupling for water connection

1. Insert the water outlet hose from the machine into the large hole of the filter unit. If needed, shorten the hose.
2. Connect the water inlet hose to the quick coupling on the recirculation pump (**C**).
3. Connect the cable from the recirculation pump to the electrical power socket of the recirculation unit inside the compartment. (**A**)
4. Connect the level sensor (**B**).
5. Make sure that the direction of the flow is as stated with an arrow on the pump. If the direction is incorrect, switch two of the phases:
 - EU cable: switch two of the phases.
 - UL cable: switch phases L1 and L2.
6. Push the unit into place in the compartment under the machine.

4.12 Adjusting disc cooling and OP-flushing

You can set the level of disc cooling and flushing time in the software.

If needed, adjust the rate of disc cooling.

Water flow regulators

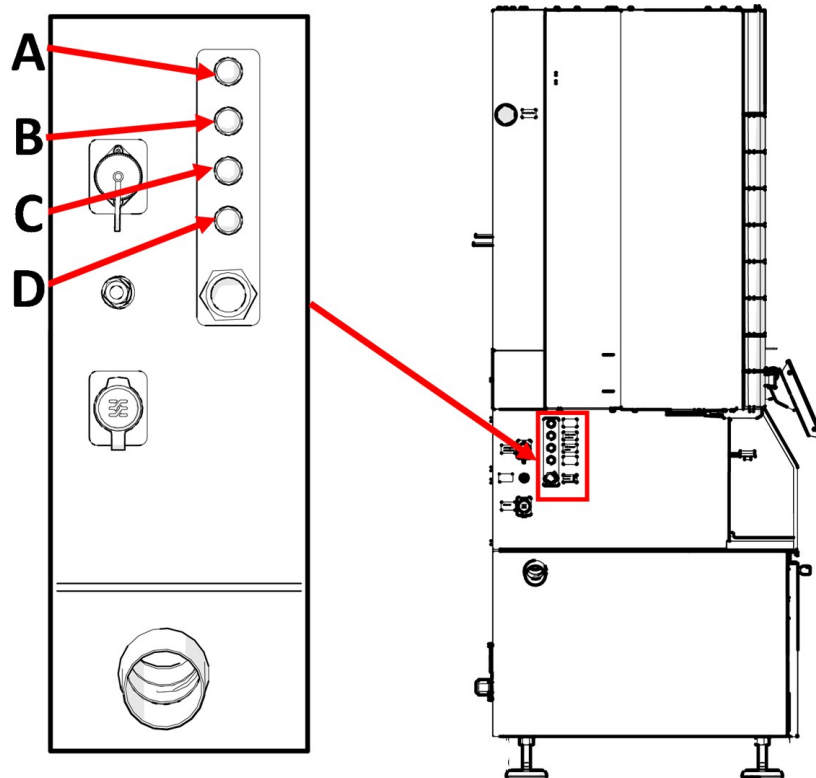

- A** OP flush water
- B** Tap water on stone
- C** MD dresser water
- D** MD disc cooling water

1. Turn the regulator to adjust the amount of water applied directly onto the grinding stone.

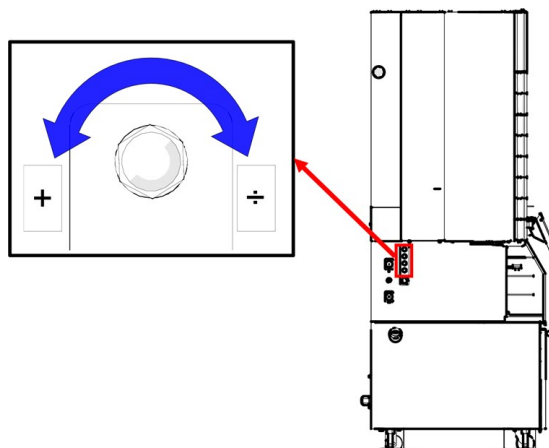

4.13 Mounting the MD-Disc



Note

Struers recommends that the MD-Disc is mounted by a service technician.

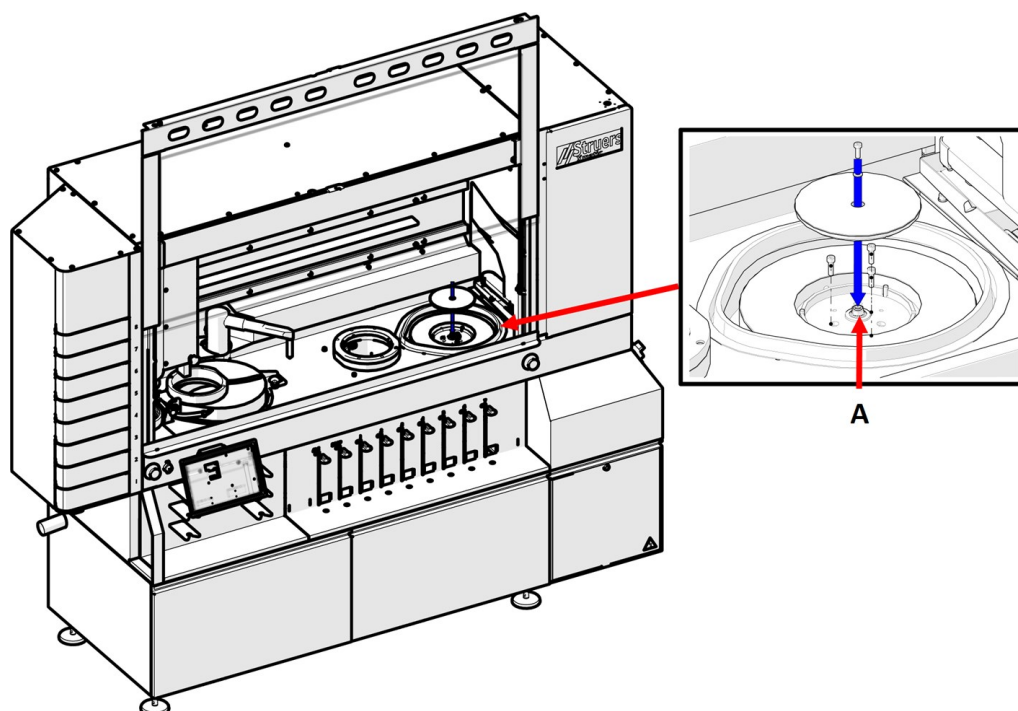

Procedure

1. Unscrew the three screws on the rear side of the MD-Disc
2. Remove the bolt and washer from the shaft [A]
3. Place the lower part of the MD-Disc in the bowl, and fasten it using the three screws you removed from the rear side of the MD-Disc
4. Place the upper part of the MD-Disc on top of the lower part, and fasten it using the bolt and washer you removed from the shaft

5 Transport and storage

If, at any time after the installation, you have to move the unit or place it in storage, there is a number of guidelines we recommend that you follow.

- Package the unit securely before transportation.
Insufficient packaging could cause damage to the unit and will void the warranty. Contact Struers Service.
- Struers recommends that all original packaging and fittings are kept for future use.

5.1 Storage



Note

Struers recommends that all original packaging and fittings are kept for future use.

- Disconnect the unit from the electrical power supply.
- Remove any accessories.
- Clean and dry the unit before storage.
- Place the machine and accessories in their original packaging.

5.2 Transport



Note

Struers recommends that all original packaging and fittings are kept for future use.

To transport the machine safely, follow these instructions.

1. Make sure that the following items are available:
 - Transport brackets (x 2)
 - Transport crossbar (x 1)
 - Bar with wheels (x 2)
 - The original pallet
2. If needed, disconnect the following:
 - Power supply



ELECTRICAL HAZARD

Disconnecting the unit from the electrical power supply must only be done by a qualified technician.

- Compressed air supply
- Water supply
- Recirculation unit. See the manual supplied with the specific equipment.
- Disconnect the monitor. This must be done by Struers Service.

- Accessories
3. Clean and dry the unit.

Requirements

- Make sure that the floor of the working area and the transportation corridor are designed to carry the following weight:

Weight	
Machine	960 kg (2116 lbs)
The weight of the specimen holders and consumables used.	

- Make sure that the following facilities are available:
 - Power supply
 - Water supply
 - Compressed air supply
 - Water drain

Moving the machine

To move the machine, use a fork-lift truck and a crossbar.



Note

The machine must be installed by Struers technicians or by an authorized service technician trained by Struers for this specific task.

1. Open the recirculation module doors .
2. Make sure that the transportation crossbar and wheels supplied with the machine are secured in position before you start lifting.
3. Loosen the brackets on the transportation crossbar to allow movement.
4. Adjust the brackets.
5. On the front of the machine, press and hold the crossbar against the bottom of the wheels.
6. Slide the brackets of the transport crossbar over the edges of the wheels and tighten the bolts.
7. Position the forklift as close to the center line of gravity as possible. See also: [Lifting ► 18](#)

6 Start-up - the first time



CAUTION

Struers equipment must only be used in connection with and as described in the Instruction Manual supplied with the equipment.

Selecting language

1. From the **Main menu**, select **User types, Administrator**. See also: [The display ► 16](#).
2. Tap the Main menu, and select Configuration.
3. Tap **Select Language**, and select the language you want to use.
4. Select whether you want to use Metric or Imperial units when working with the machine.

6.1 Mounting the grinding stone or diamond grinding disc



CAUTION

Do not use the machine with non-compatible accessories or consumables.

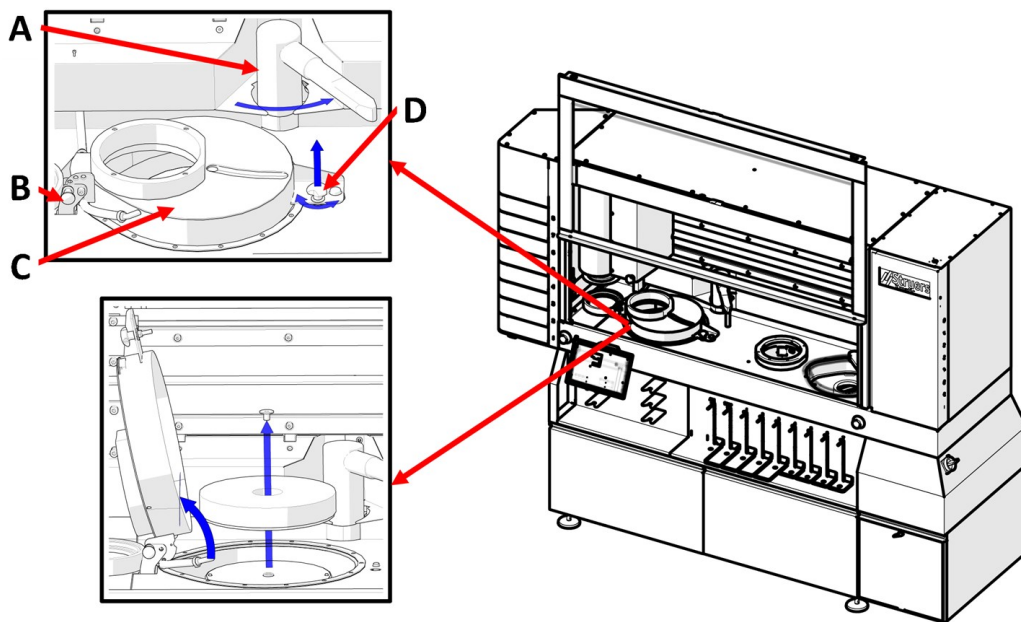

- A Grinding stone dresser
- B Index plunger
- C Grinding stone cover
- D Three-lobe knob

Procedure

1. Log in to the machine as **Administrator**.
2. In the consumables ribbon, tap the stone icon.

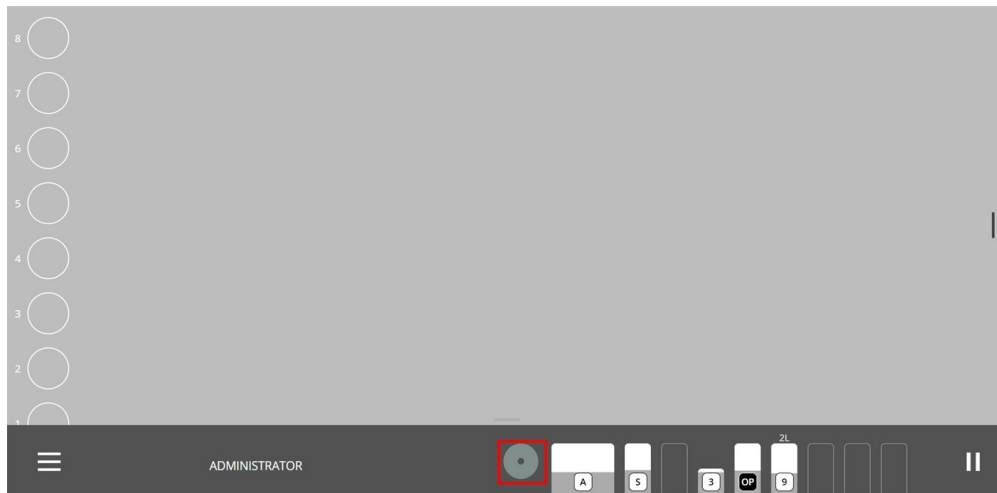

3. Tap **Change**.

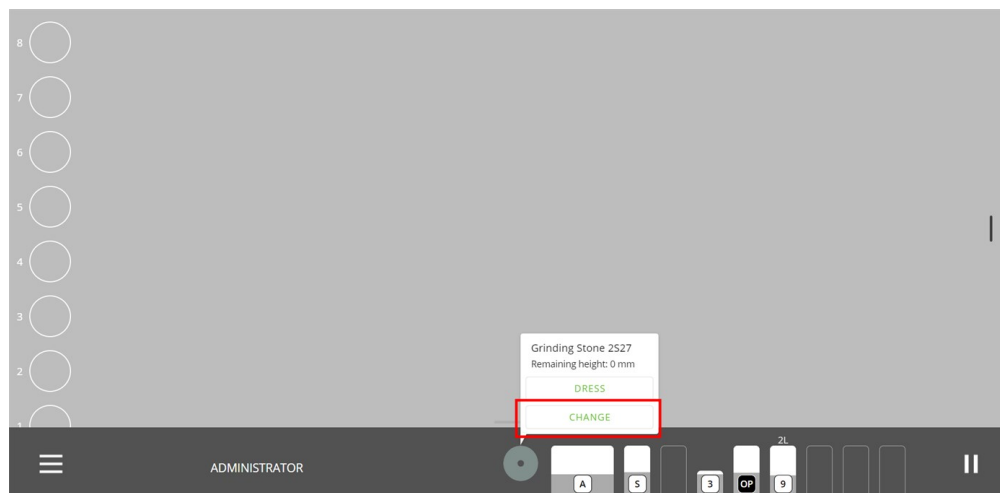

4. Open the main safety cover
5. Loosen and lift the three-lobe knob. **(D)**
6. Pull the index plunger **(B)**, and lift the grinding stone cover. **(C)**

7. Use the 8 mm Allen key to remove the screw and washer.
8. If there is a grinding stone in the stone module, remove it.

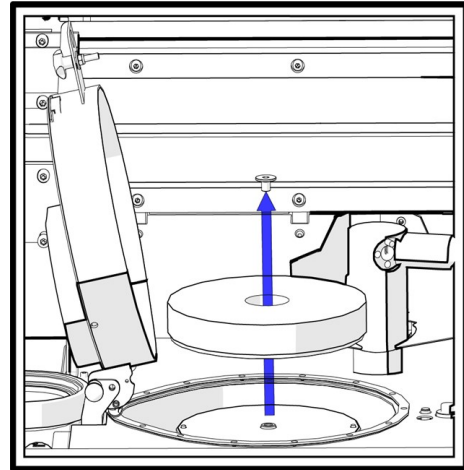

9. Place the grinding stone or diamond grinding disc on the driving plate.
10. Make sure that the two pins from the driving plate engage in the two holes at the bottom of the grinding stone or diamond grinding disc.
11. Remount the washer and the screw and securely tighten the screw with the 8 mm Allen key.
12. Release the index plunger and lower the cover over the grinding stone.
13. Tighten the three-lobe knob.
14. Close the main hood.

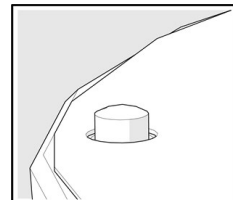
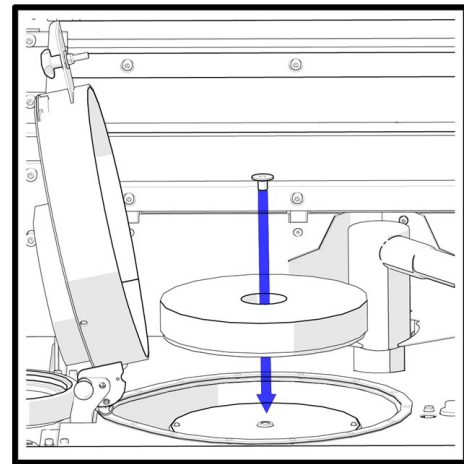

When you have selected a grinding stone or diamond grinding disc on the screen, the dresser automatically moves to detect the top of the stone. When the top of the stone has been detected the dresser moves into its parking position.

Hint

 If you select a diamond grinding disc, the dresser remains at the side of the grinding chamber because it is not used.

Hint

 Struers recommends that you dress a new stone a couple of times before using it for grinding. This will ensure that it is plane and ready for use.

6.2 MD surfaces

CAUTION

 Do not use the machine with non-compatible accessories or consumables.

The MD surfaces are placed on shelves in the MD elevator.

The MD elevator has several shelves that contain individual MD grinding or polishing surfaces to be used for the different steps in a method. If you are using Struers surfaces, the machine automatically detects the type of surface placed on each shelf.

After using an MD polishing surface once, the machine will indicate the size of the abrasive used with the specific MD polishing surface.



Note

The machine has been configured to be use with either 250 mm or 300 mm MD surfaces. You cannot use a mix of the two diameters.

Procedure

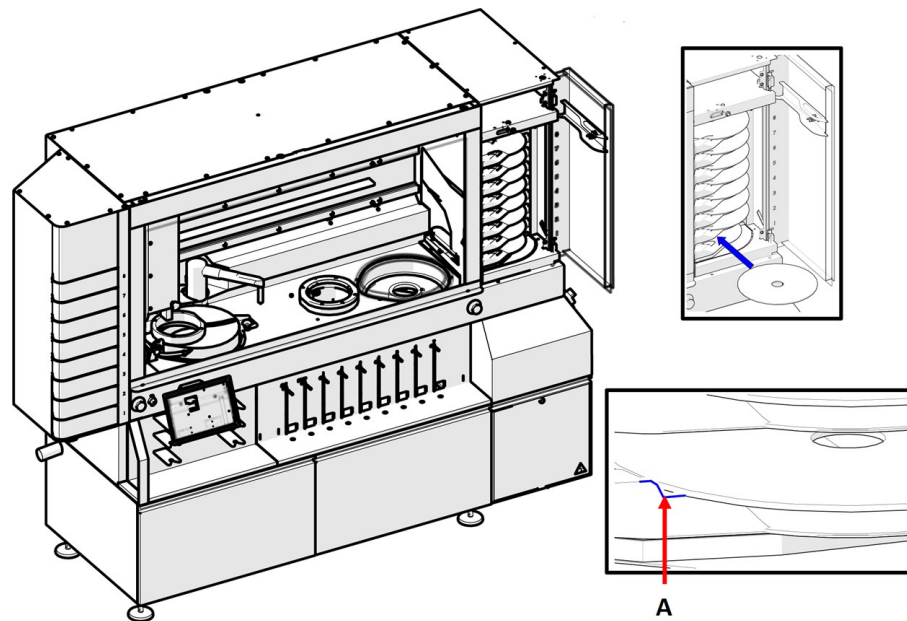

1. Open the MD elevator door
2. Place the surface on the desired shelf as shown in the illustration.
Make sure that the surface is placed inside the small indentations on the shelf **[A]**.
3. Close the MD elevator door to start the surface detection.

6.3 Bottle rack

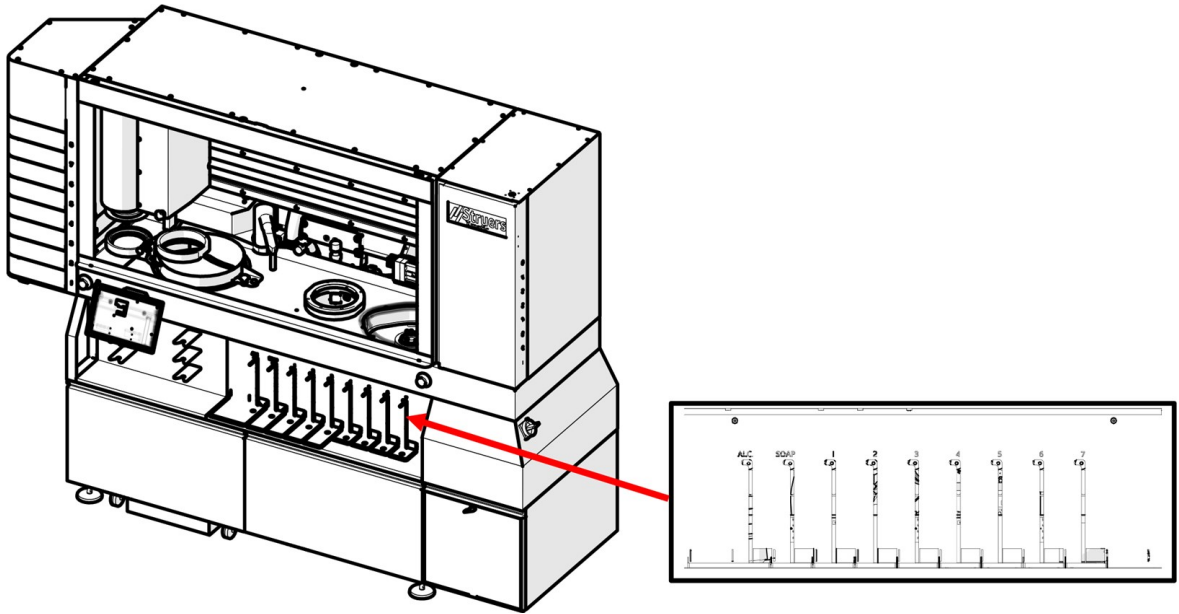

The machine has 9 pumps

Bottle position 1 and 2:

Alcohol/Soap

Pumps 3-9

Suspension, lubricant or oxide polishing.

6.3.1 Placing bottles in the bottle rack module

If you are using Struers consumables, the machine will automatically detect the type of consumable and liquid levels of the bottles.



Note

Positions 1 and 2 are for Alcohol/Soap only.

1. Place the bottle guides on the bottle rack.
2. Place the bottles in the bottle guides with the Data Matrix code facing the machine.
3. Connect the Easy Connector to the bottles.
4. Check the consumables ribbon to make sure that the machine has detected the installed consumables.

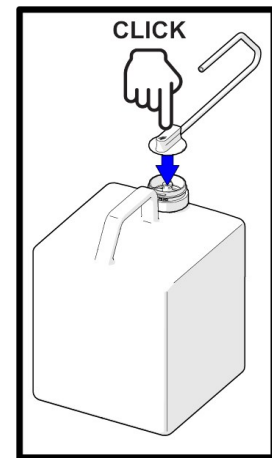

6.3.2 Soap and alcohol



CAUTION
An exhaust system is required.



CAUTION
Do not use the machine with non-compatible accessories or consumables.

Filling the soap and alcohol bottles

1. Fill the soap bottle.
2. Fill the empty bottle supplied with the machine with an ethanol and propanol solution.

Monitoring the soap and alcohol levels

The machine automatically monitors the soap and alcohol levels.

7 Configuration



Note
Only users with Administrator rights can configure the machine.

1. In the Main screen, select Administrator.
2. Tap the Main menu icon.
3. Select Configuration

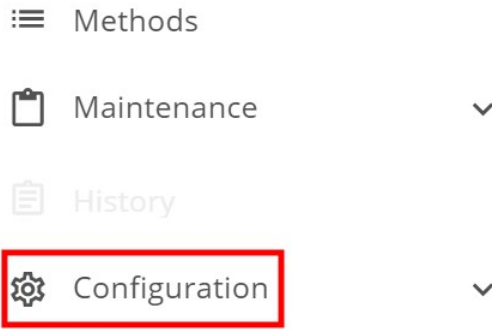

4. In the **Configuration** screen, you can access the following submenus:
- Preparation
 - Cleaning templates
 - Machine settings
 - System settings

7.1 Preparation

Configuring Dresser programs



Note

You need Administrator access to adjust the settings for dressing of the grinding stone.

1. Log in to the machine as **Administrator**.
2. From the **Main menu** select **Configuration**.
3. Select **Preparation > Stone** to open the dresser program list.

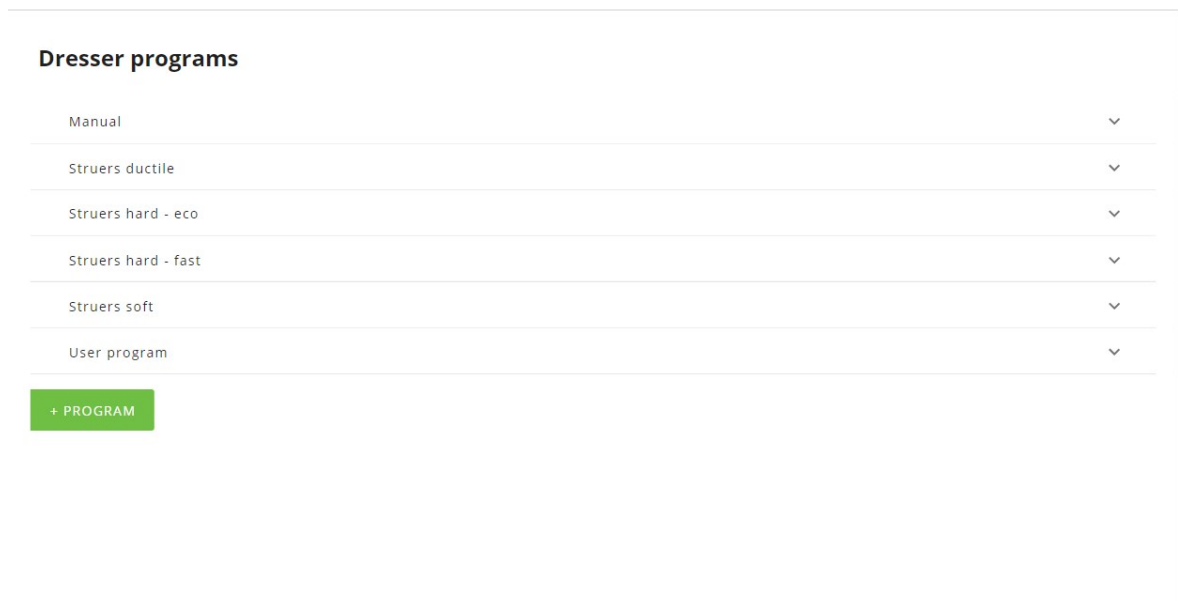

The list shows a number of default dresser programs that cannot be changed. The only exception is the **Manual** dressing program.

The **Manual** dressing program is used whenever you select **Dress** in the consumables ribbon.



To create a new dresser program, tap the +Program button. This adds a new dresser program to the list

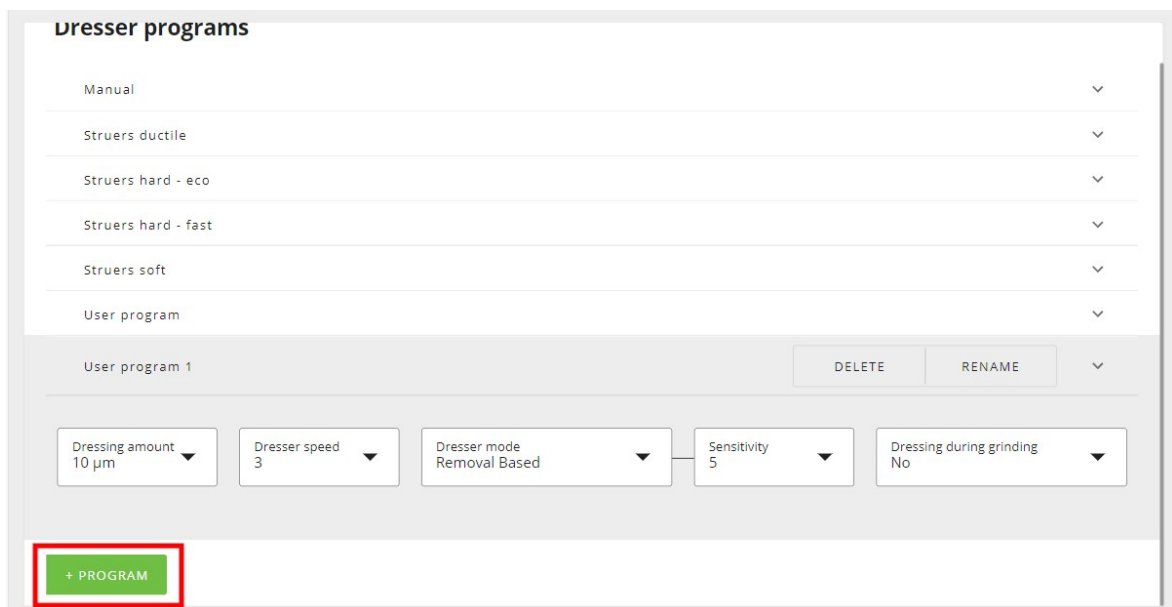

4. Adjust the settings as desired. All changes are automatically saved.

Dresser templates	
You can select among one of the following dresser templates:	
<div style="border: 1px solid blue; padding: 5px;"> <p>Note Dressing after process is selected independently in the preparation method.</p> </div>	
Manual	Adjust the settings as desired.
Struers ductile	Use this dresser template for grinding with a consumable suited for ductile materials as nickel-based alloys and stainless steel.

Dresser templates	
Struers hard	<p>Struers hard - eco</p> <p>Use this dresser template for grinding with a consumable suited for hard and very hard metals.</p> <p>When you use this dresser template, a smaller amount of dresser is applied, and the speed and sensitivity are also lower, thus prolonging the lifespan of the grinding stone.</p> <p>Struers hard - fast</p> <p>Use this dresser template for grinding with a consumable suited for very hard metals.</p>
Struers soft	Use this dresser template for grinding with a consumable suited for soft, non-ferrous metals.

Dressing amount
<ul style="list-style-type: none"> Set a value in microns from 10-300 for how much you want to remove.

Dresser speed
<ul style="list-style-type: none"> Set the speed of dressing from 1-10.

Dresser mode	
Select between Removal based , or Time based .	
Removal based	<p>Select the desired sensitivity from 1-20.</p> <p>The higher the sensitivity, the more often the stone is dressed.</p>
Time based	<p>Select the desired dressing interval from 10 seconds to 5 minutes.</p> <p>The stone is dressed after the selected dressing interval. This process is cyclic.</p>

Sensitivity
Select the desired sensitivity setting.

Dressing during grinding
<p>Select Yes to have the stone dressed while the material removal is running.</p> <p>Select No to lift the specimen holder when dressing the stone</p>

7.1.1 Manual dressing

Struers recommends that you dress a new stone a couple of times before using it for grinding. This ensures that it is plane and ready for use.

Settings

Dresser step	
<p>To obtain an active and plane grinding stone surface, make sure that the dresser steps are large enough to adequately dress the grinding stone.</p> <p>To obtain the longest possible lifetime of the grinding stone, make sure that the dresser steps are as small as possible.</p>	
Dresser step	<ul style="list-style-type: none"> From 20 to 100 μm, in intervals of 10 μm..
Rotate Time	
Rotate Time	<p>Set the rotation time.</p> <ul style="list-style-type: none"> From 1 to 9 minutes, in steps of 1 min.

Procedure

1. Log in to the machine as **Administrator**.
2. From the **Main menu** select **Configuration**.
3. From the **Configuration** menu, select **Configure Dressing**.
4. Select **Manual dress**. The **Dressing and Stone Check** screen is shown.
5. Select **Dress grinding stone** to start the dressing process.
6. Set **Rotate Time**.

When a new grinding stone has been installed, you can rotate the grinding stone for a specified period of time to make sure that the grinding stone is not damaged and is rotating correctly.

7. Select **Rotate grinding stone** to start the process.

7.2 Machine settings

Configuring machine settings

1. Log in to the machine as Administrator.
1. From the **Main menu** select **Configuration**.
2. From the **Configuration** menu, select Machine settings.

The Machine settings menu is shown.

✕ Machine configuration

Configuration > Machine

General

<p>Feeder</p> <p>Eject empty tray Automatic ▼</p> <p>Specimen holder diameter 160 Mm ▼</p>	<p>Liquid</p> <p>Measure liquid levels Automatic ▼</p>
<p>MD Changer</p> <p>Read all MDs Automatic ▼</p>	<p>Reference search</p> <p>Threshold — 0 +</p> <p>Counter — 1 +</p>
<p>Stone</p> <p>Measure dresser tip and stone height Automatic ▼</p>	

3. Adjust the settings as desired. All changes are automatically saved.

- | |
|--|
| Eject empty tray |
| <ul style="list-style-type: none"> Select whether the drawer should be ejected automatically if you close it without any specimen holder present in the drawer. |
| Specimen holder diameter |
| <ul style="list-style-type: none"> You can define the default diameter of your specimen holders, or you can set the machine to automatically detect the diameter of the specimen holders. |
| MD elevator |
| <ul style="list-style-type: none"> Select whether the machine should automatically read all MD surfaces when you place them on the MD elevator. |
| Stone |
| <ul style="list-style-type: none"> Select whether the machine should .automatically measure the dresser tip and stone heighth. |
| Liquid |
| <ul style="list-style-type: none"> Select whether the machine should automatically read the liquid levels in the bottles placed in the bottle rack. |

7.3 Cleaning templates

The software contains predefined Struers cleaning programs which can be used for most requirements, but you can also create your own cleaning programs.

Configuring cleaning templates

1. Log in to the machine as **Administrator**.
2. From the **Main menu** select **Configuration**.
3. Select **Cleaning templates**.

The **Cleaning templates** menu is shown.

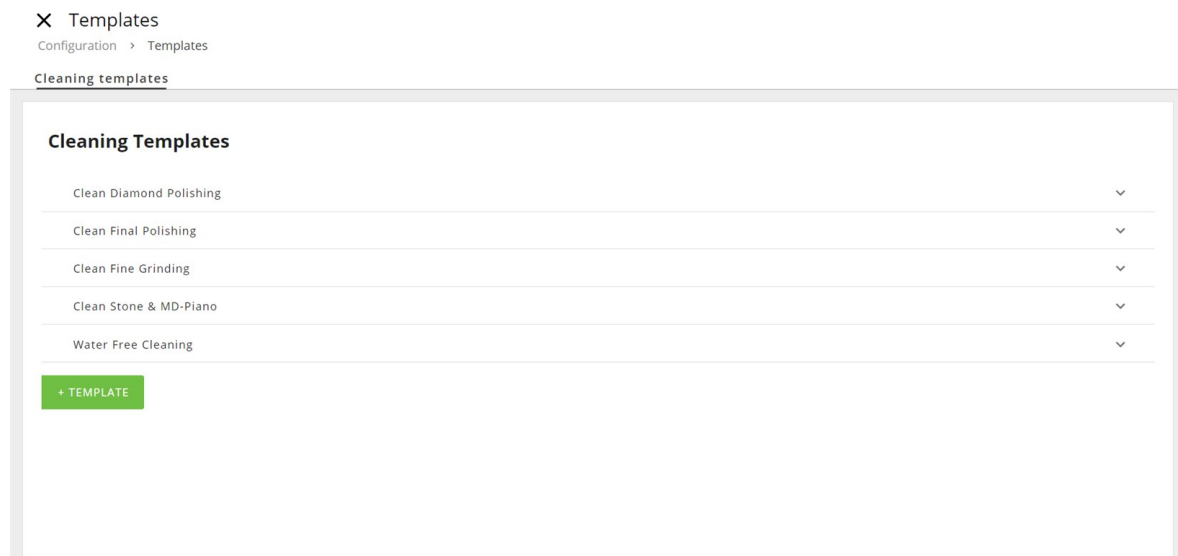

4. Select the desired cleaning template.

A drop-down list opens.

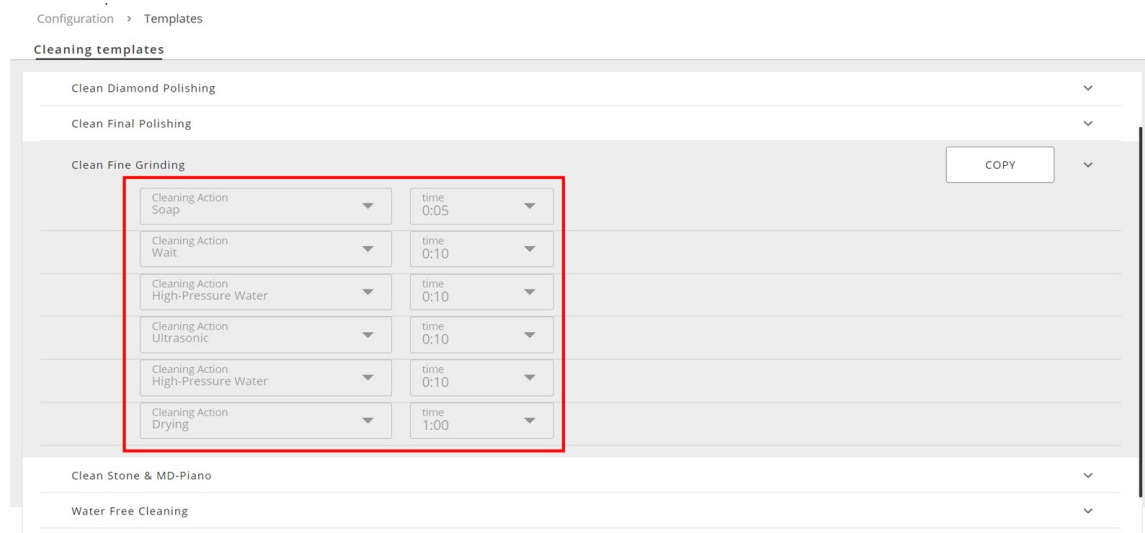

5. Adjust the different parameters as desired.
The machine saves your changes automatically.

 **Note**
You can also copy a cleaning template and use it to create your own cleaning template.

7.3.1 Creating cleaning templates

You can copy an existing cleaning template and use it as a starting point when creating your own.

Configuring cleaning programs

1. Log in to the machine as **Administrator**.
2. From the **Main menu** select **Configuration**.
3. Select **Cleaning templates**.

The **Cleaning templates** menu is shown.

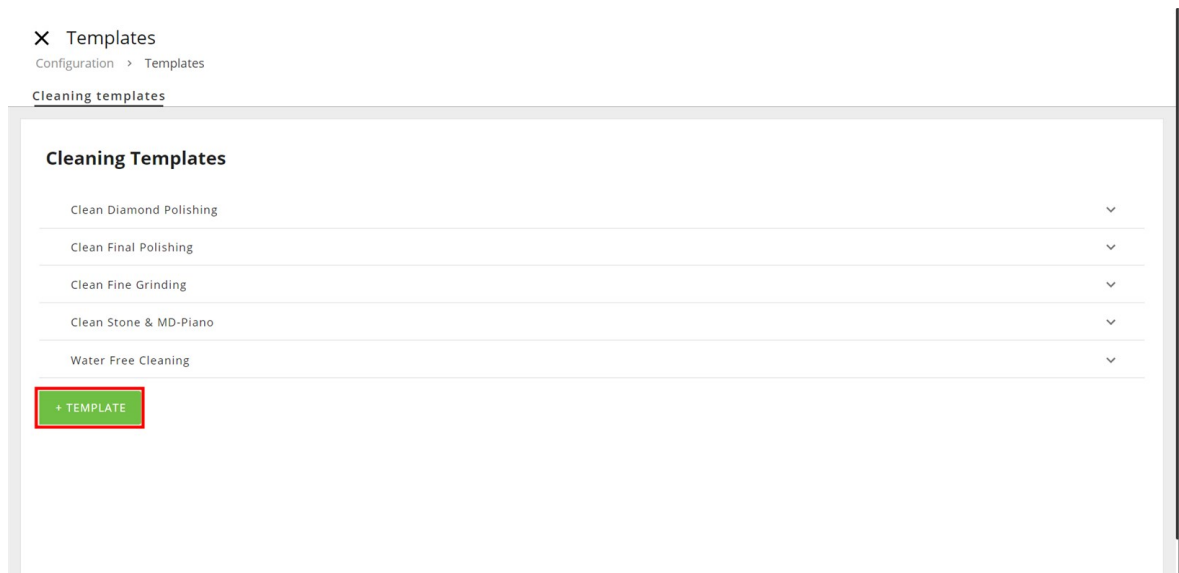

4. Tap **+Template** to add a new template, and adjust the parameters as desired.
5. Tap **Copy**.

 **Note**
You can only copy Struers predefined cleaning templates.



In a user-defined template, you can:

- Adjust any parameter
- Rename the template
- Add cleaning steps
- Delete the template

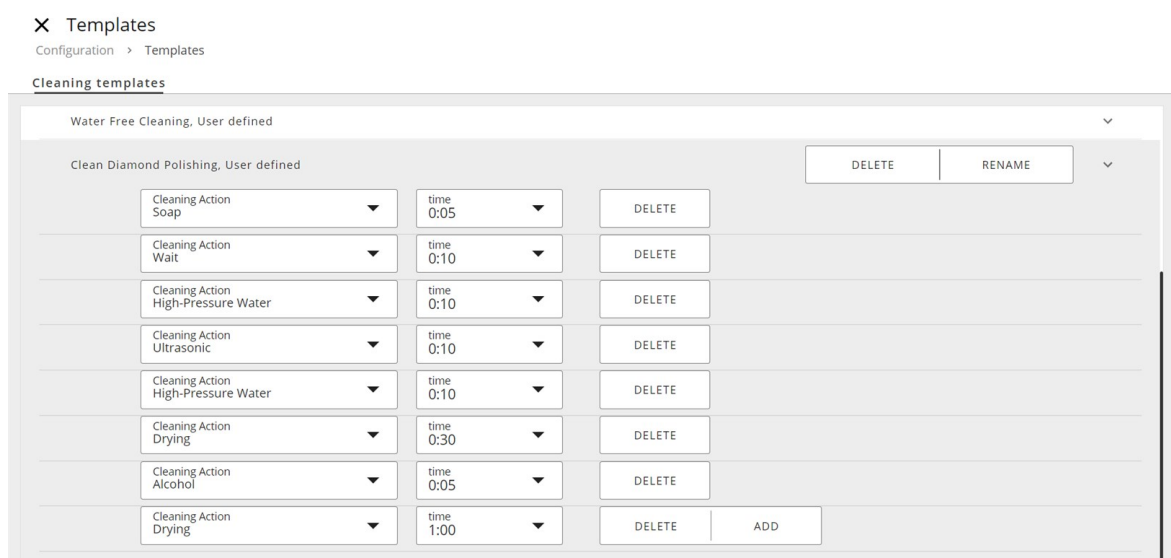

8 Operating the device



WARNING

If power is interrupted under operation, the main safety cover and the MD elevator door will remain locked until power returns. See: [Accessing the work zone in case](#)

▶ 79.



CAUTION

Do not use the machine with non-compatible accessories or consumables.

8.1 Clamping and leveling specimens



CAUTION

Do not use the machine with non-compatible accessories or consumables.

Make sure that the specimens are firmly clamped in the specimen holder, and that they are level.

8.2 Placing and removing the specimen holder in/from the vertical conveyor



CRUSHING HAZARD

Take care of your fingers when handling the machine.

Always wear safety shoes when handling specimen holders, as they can be heavy.



CAUTION

Wear suitable gloves to protect fingers from abrasives and warm/sharp specimens.

The vertical conveyor drawers have three different positions. Each position indicates a certain state on the machine:

- **Open:** The drawer is ready to be used.
- **Partially open:** The specimen holder is ready for inspection, or the drawer is empty.
- **Closed:** The machine is processing the specimen holder you placed in this position.

Placing the specimen holder in the vertical conveyor

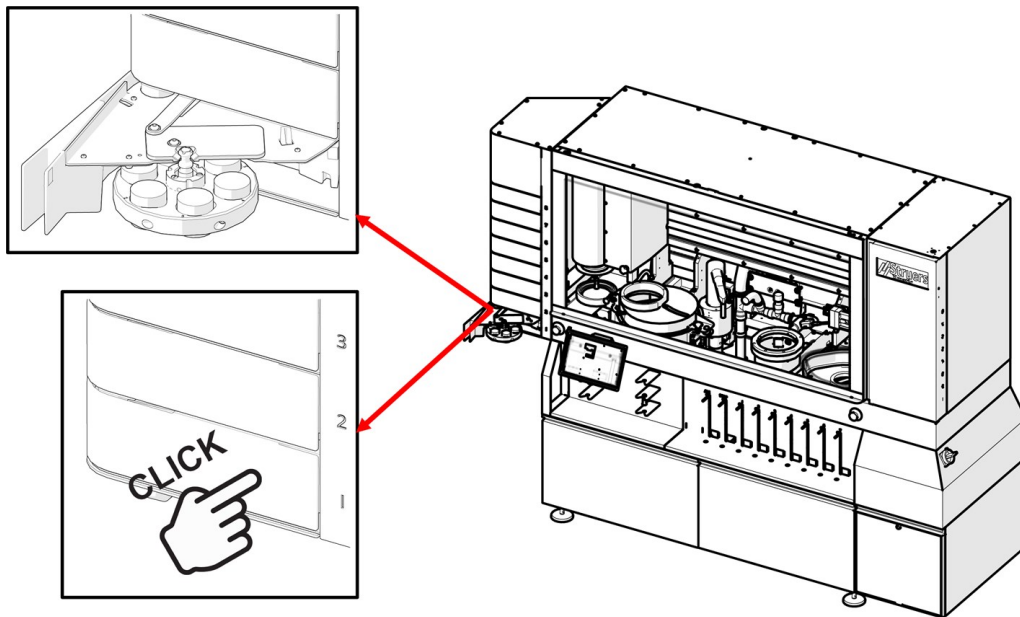

1. If the drawer is empty, open it by tapping its icon on the main screen. See also: [The display ► 16](#).

If the drawer is closed and a specimen holder is present, tap its icon on the main screen, and tap the **Eject** icon. See also: [Removing the specimen holder from the vertical conveyor ► 51](#)

If the drawer is partially open, pull it open.

2. Pull the drawer open.
3. Place the specimen holder as shown in the illustration, and close the drawer.

The machine automatically detects the specimen holder.

Removing the specimen holder from the vertical conveyor

When a specimen holder has been processed, the machine automatically opens the drawer to the partially open position.

Open the drawer and remove the specimen holder.

If the specimen holder has not been processed yet, the drawer remains closed. To open it, tap the specimen holder icon, and select the **Eject** icon.



Open the drawer and remove the specimen holder.

8.3 Methods

8.3.1 Struers methods

You can access all Struers methods in the **Method Library**.

Procedure

1. Place a specimen holder in the desired position.
The machine shows the latest applied method as default.
2. Tap the method name on the screen.

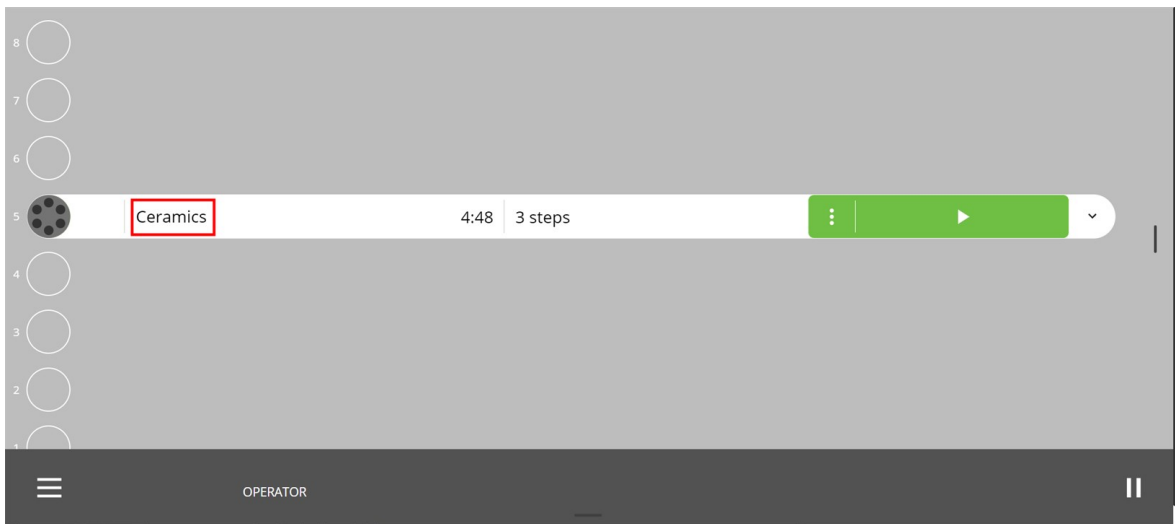

The **Methods** screen opens.

3. Tap the **Library** tab

✕ Filter the methods by material, preparation request and other tags

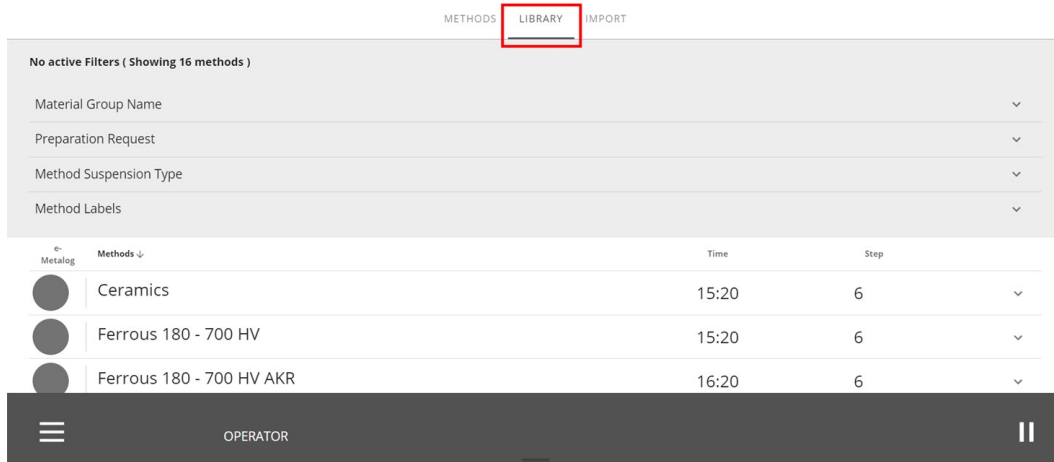

4. Select the desired method, or use the filter tools to locate the desired method.

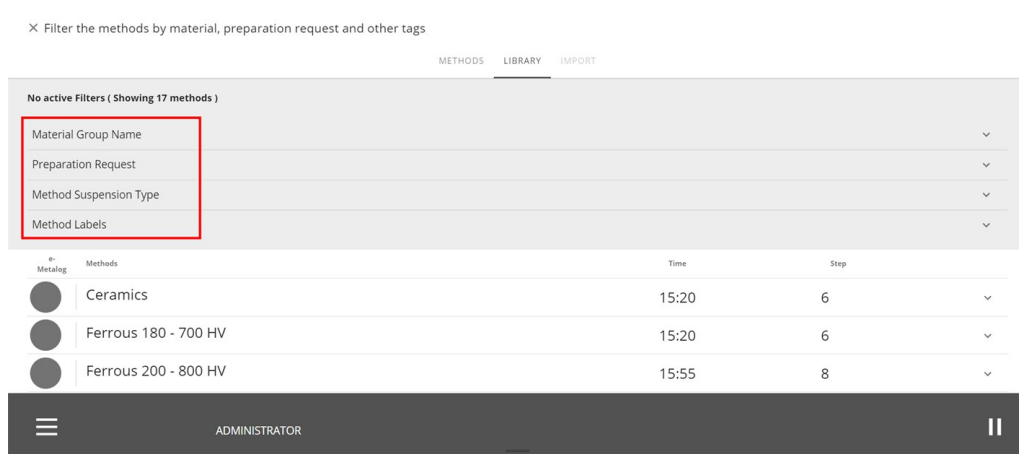

Applying filters

You can apply filters to the Struers method library to find the best method for the task you need to perform.

You can apply filters using the following criteria:

- Material group names
- Preparation requests
- Method suspension type
- Method labels

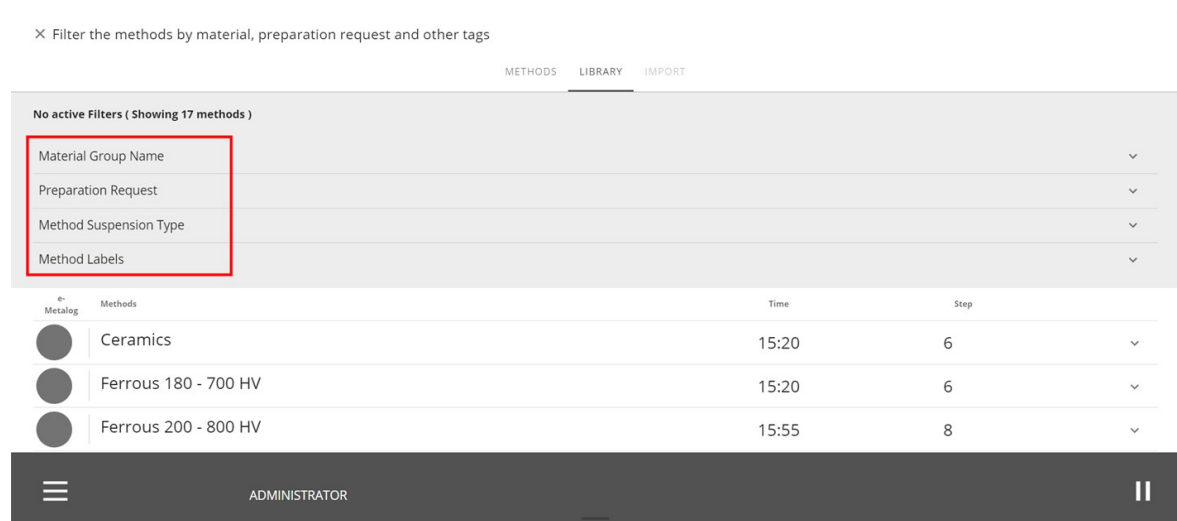

8.3.2 Custom methods

Creating custom methods

You can create your own methods by copying a Struers method and adding or modifying steps.

Custom methods are saved in the **Methods** tab.

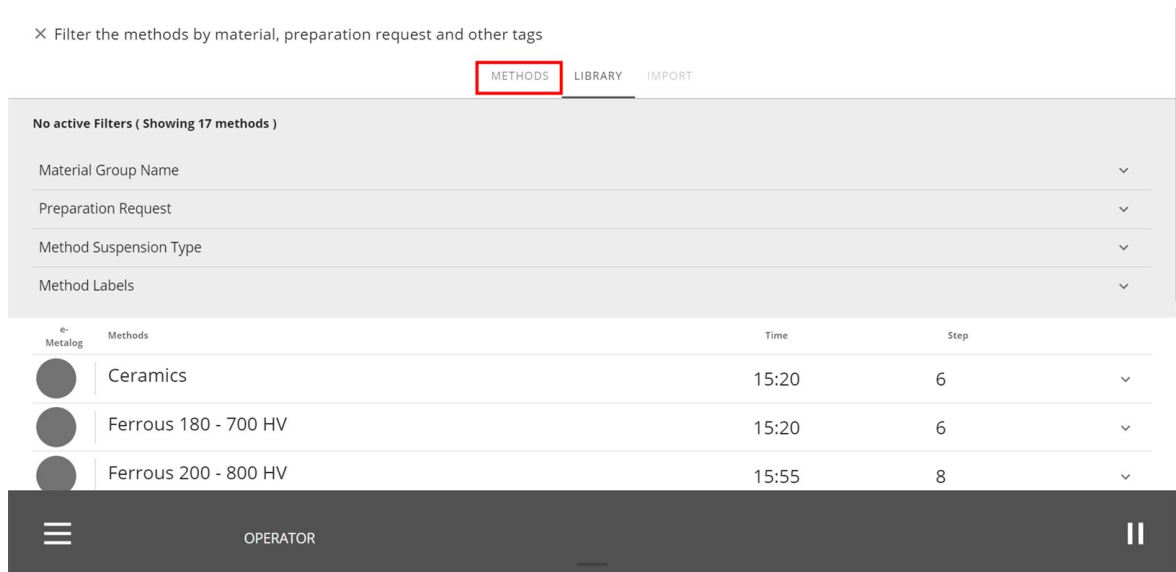

Editing a method

You can edit a method before starting the preparation process, and while the preparation process is running.

Editing a method before starting the preparation process

1. Log in to the machine as **Administrator**.
2. Place a specimen holder in the desired position.
The machine shows the latest applied method as default.
3. Tap the method name.

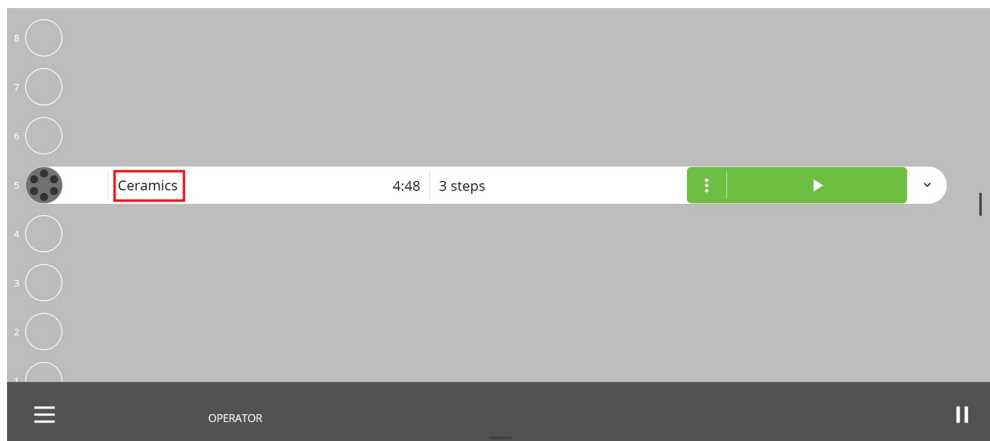

4. Tap **Methods** to open the User-defined methods library, or tap **Library** if you want to open the Struers methods library.
5. Select the method you want to edit.

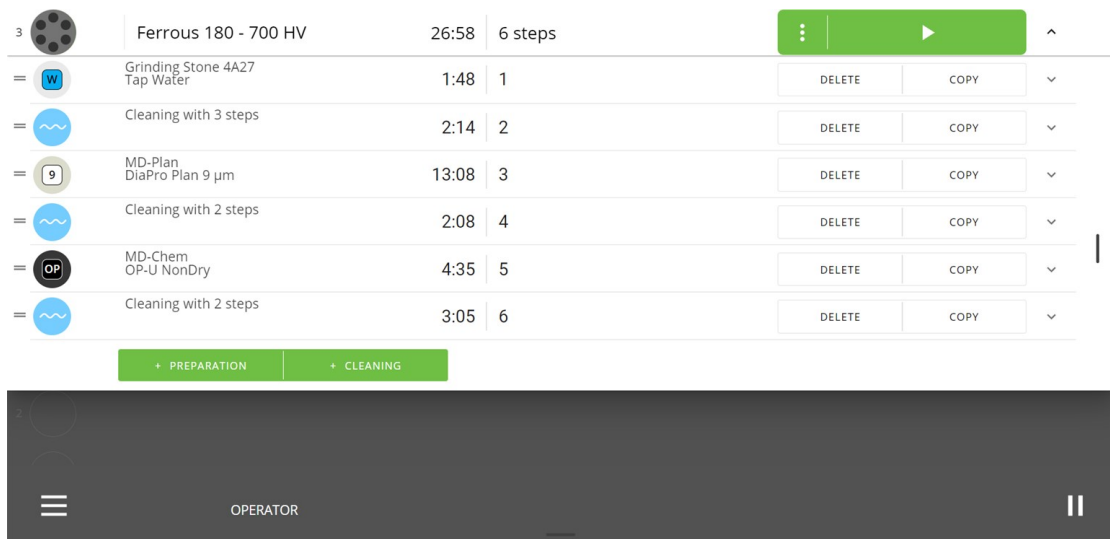

6. You can **Delete** or **Copy** steps, and you can add **Preparation** and **Cleaning** steps as desired.
7. When you finish editing, you can save your changes.

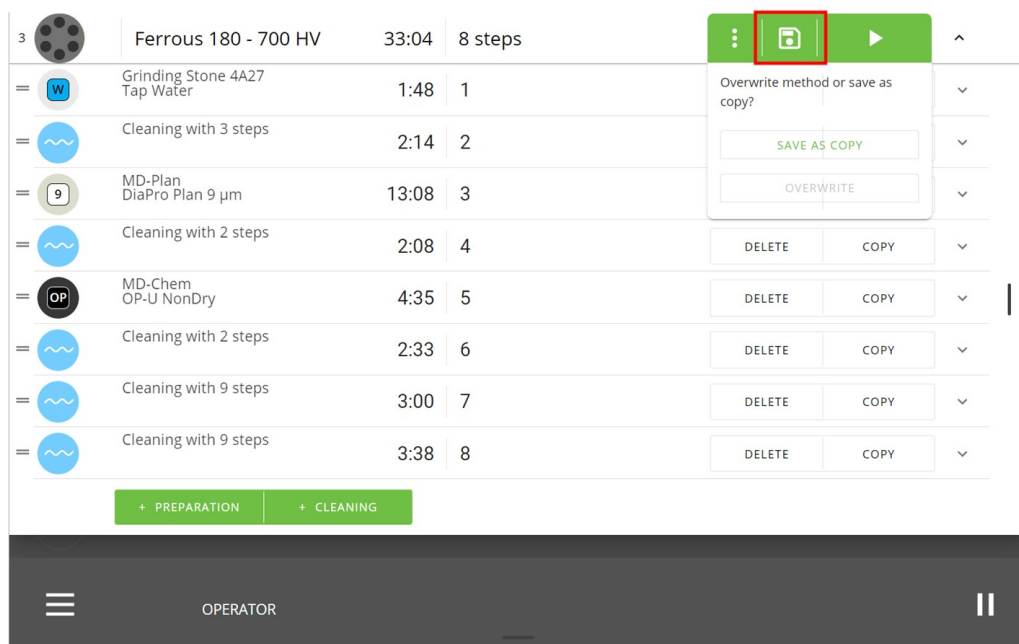

Editing a method without placing a specimen holder in the machine

1. Log in to the machine as **Administrator**.
2. Tap the **Main menu** icon. See also: [The display ► 16](#).
3. Tap **Methods**.

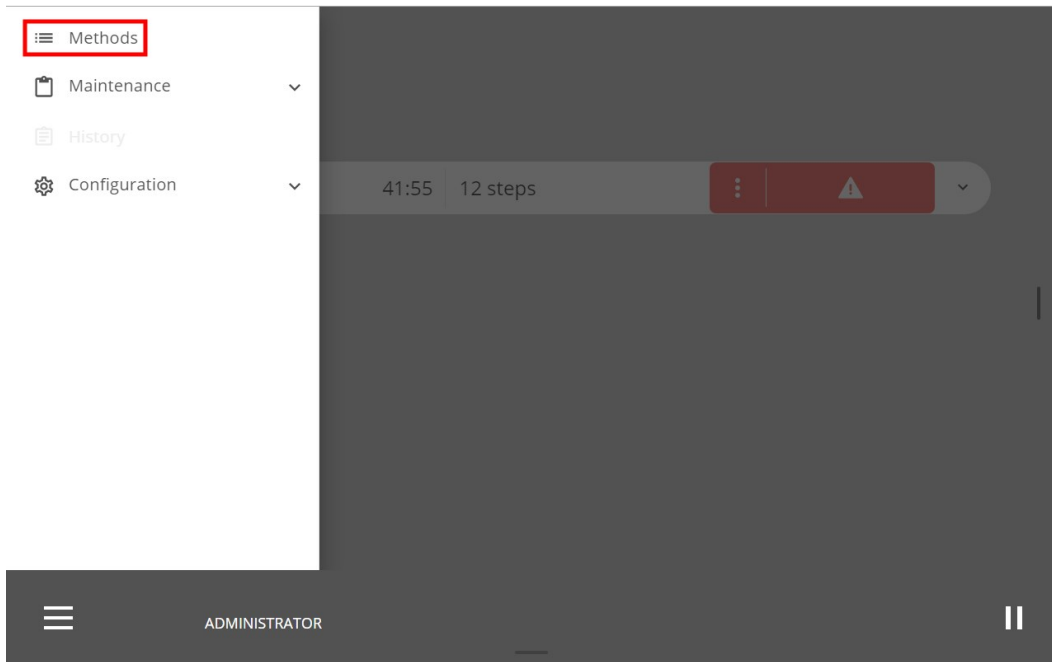

4. Tap **Methods** to open the User-defined methods library, or tap **Library** if you want to open the Struers methods library.
5. Select the method you want to edit.
6. You can **Delete** or **Copy** steps, and you can add **Preparation** and **Cleaning** steps as desired.
7. When you finish editing, you can save your changes.

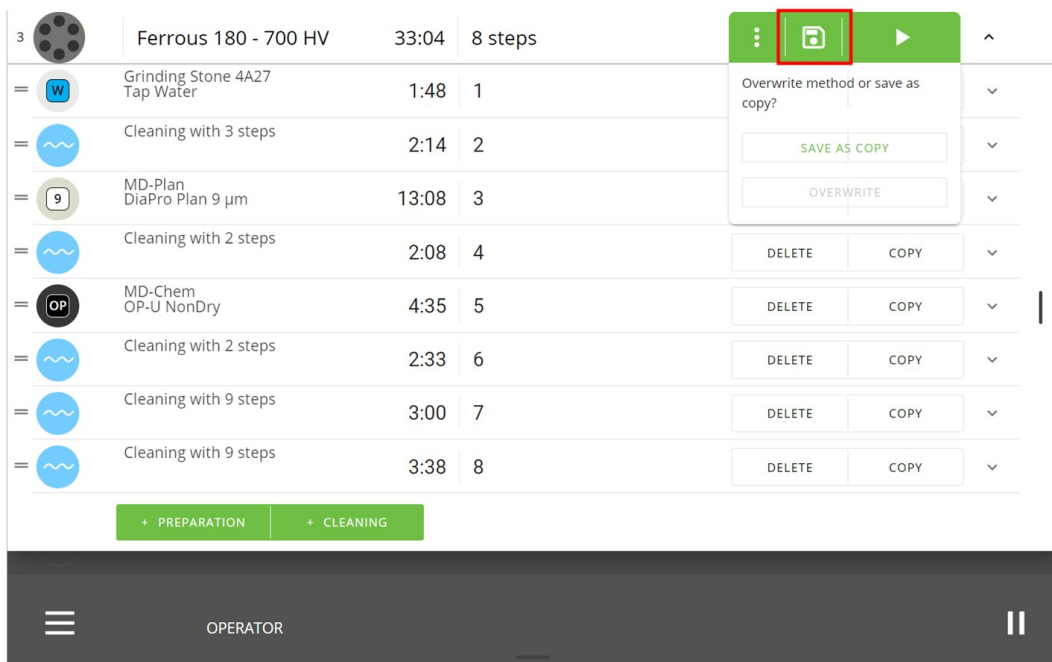

8.4 The preparation process

Use the **Preparation** for the daily preparation work.

8.4.1 Consumables

8.4.2 Starting the preparation process



CAUTION

Wear suitable gloves to protect fingers from abrasives and warm/sharp specimens.

Before you start the preparation process, you can see a list of the different preparation steps by tapping the drop-down icon. See: [The display ▶ 16](#).

When the method is running, the progress of the preparation is shown with the time counting down to 0.

1. Log in to the machine as Administrator or **Operator**.
1. Select the desired method.
2. Make sure that all the necessary consumables and MD surfaces are available on the machine.

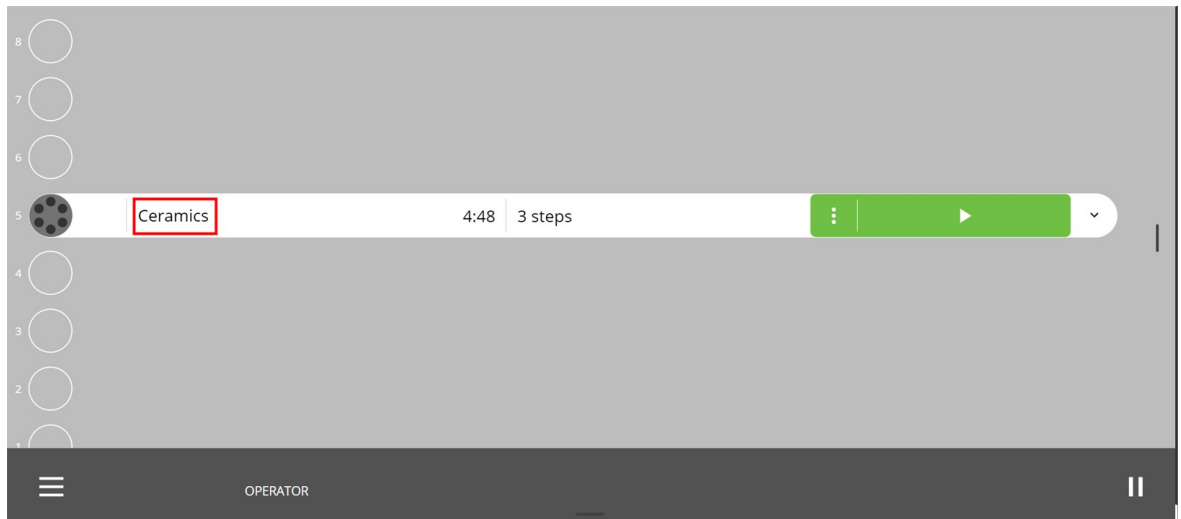

3. Tap **Run**.

The machine stops automatically when the process is completed.



Note

If you have placed several specimen holders in the vertical conveyor, the specimen holders are queued based on the order in which you have pressed **Run** for each of the specimen holders.

To modify the queue, tap **Eject**, and press **Run** for each specimen holder in the order you want them to be processed.

9 Maintenance and service - Xmatic

Proper maintenance is required to achieve the maximum up-time and operating lifetime of the machine. Maintenance is important in ensuring continued safe operation of your machine.

The maintenance procedures described in this section must be carried out by skilled or trained personnel.

Safety Related Parts of the Control System (SRP/CS)

For specific safety related parts, see the section "Safety Related Parts of the Control System (SRP/CS)" in the section "Technical data" in this manual.

Technical questions and spare parts

If you have technical questions or when you order spare parts, state serial number and voltage/frequency. The serial number and the voltage are stated on the type plate of the machine.

9.1 General cleaning

To ensure a longer lifetime for your machine, Struers strongly recommends regular cleaning.



Note

Do not use a dry cloth as the surfaces are not scratch resistant.



Note

Do not use acetone, benzol or similar solvents.
Do not use any abrasive agents when cleaning the machine.

If the machine is not to be used for a longer period of time

- Clean the machine and all accessories thoroughly.

9.2 When necessary

The frequency with which some maintenance and cleaning procedures should be carried out depend on how often and how you use the machine.

9.2.1 Air filter

Clean the air filter carefully using a soft brush.

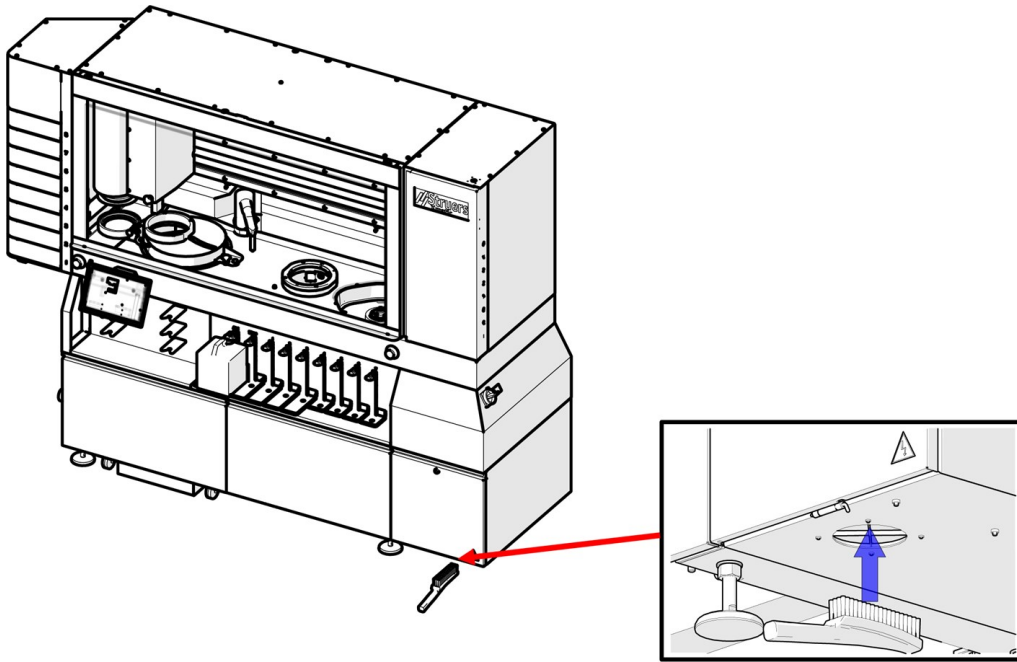

9.2.2 Cleaning the MD-Disc

**Note**

Do not use a dry cloth as the surfaces are not scratch resistant.

**Note**

Do not use acetone, benzol or similar solvents.

- Wipe the MD-Disc clean using a damp cloth.

The bowl liner

Cleaning the bowl liner

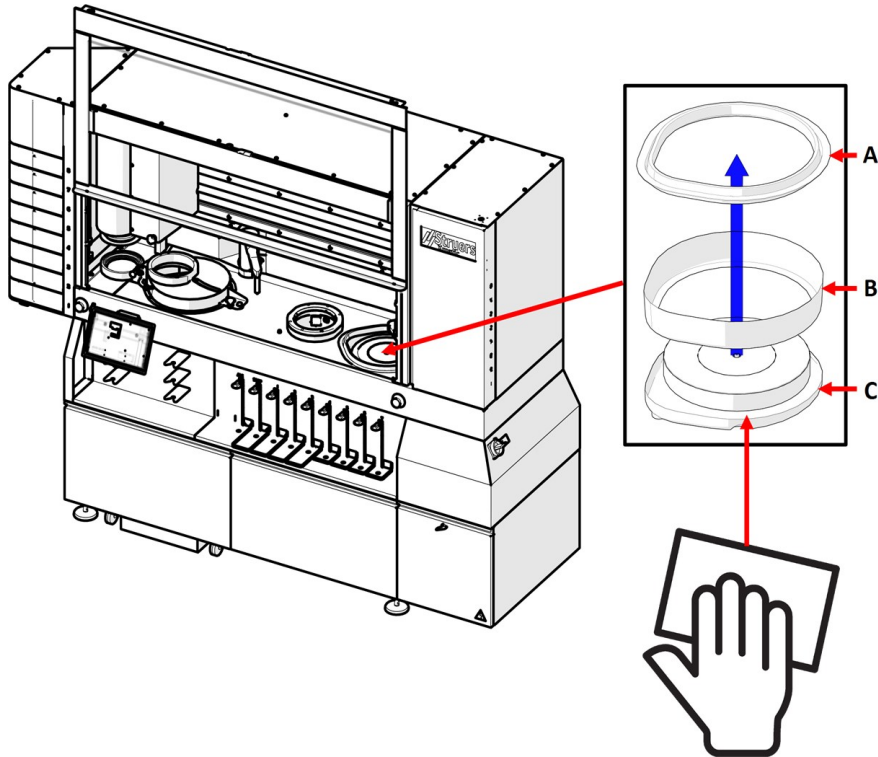

1. Remove the splash guard. **(A)**
2. Remove the upper part of the bowl liner and wash it. **(B)**
3. Wipe the lower part of the bowl liner using a damp cloth. **(C)**
4. Remount the upper part of the bowl liner and the splash guard.

Replacing the bowl liner

If the bowl liner is damaged, replace it with a new one, and dispose of the damaged bowl liner according to local regulations.

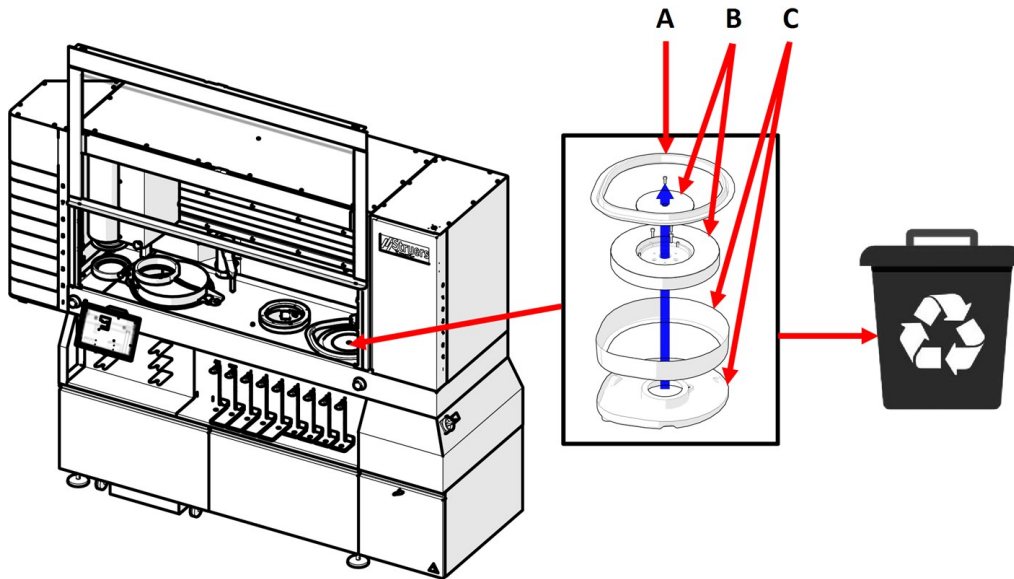

1. Remove the splash guard. (A)
2. Remove the MD Disc. See also: [Mounting the MD-Disc ▶ 33](#).
3. Remove the used bowl liner (C), and ,mount the new one.
4. Remount the splash guard.
5. Dispose of the used bowl liner according to local regulations.

9.2.3 Cleaning the grinding stone station



CAUTION

Avoid skin contact with the cooling fluid additive.



Note

Do not use a dry cloth as the surfaces are not scratch resistant.



Note

Do not use acetone, benzol or similar solvents.



Hint

If needed, use ethanol or isopropanol to remove grease and oil.

For more information on how to open the grinding stone cover, and how to remove the stone before cleaning, see: [Mounting the grinding stone or diamond grinding disc ▶ 36](#).

Cleaning the grinding stone/diamond grinding disc

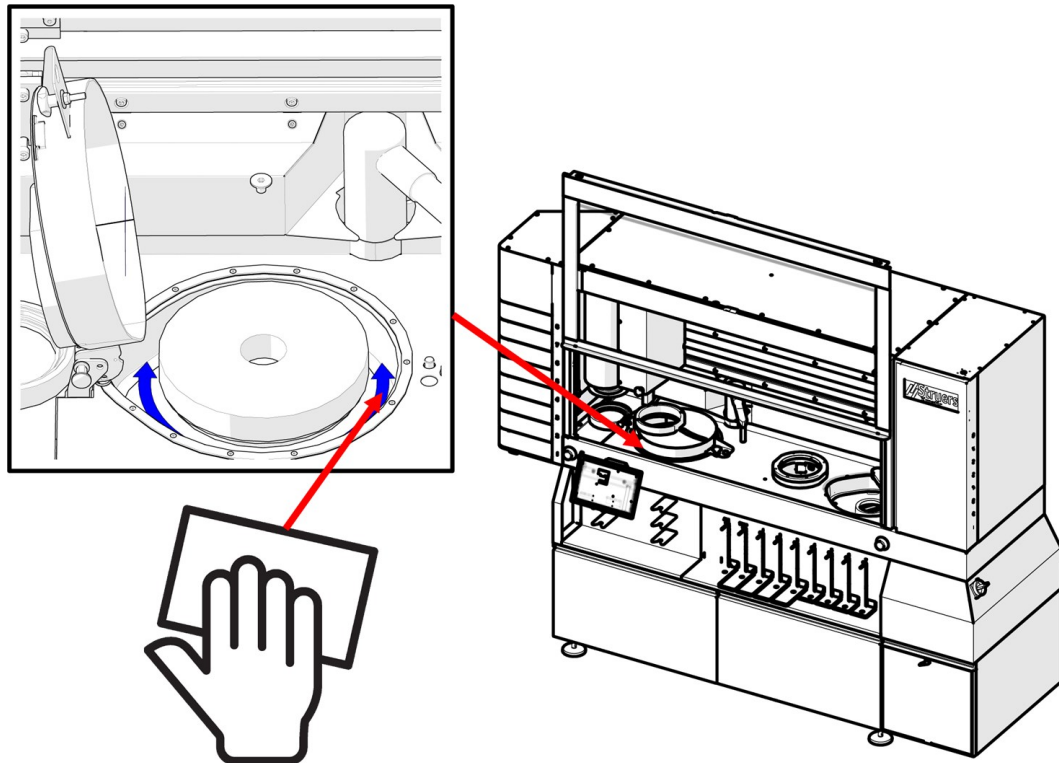

- Wipe the bowl clean using a cloth.
If necessary, you can remove the stone before cleaning. See also: [Mounting the grinding stone or diamond grinding disc](#) ► 36.

Changing the bowl liner

Note
You cannot change the bowl liner yourself - this must be done by a service technician.

9.2.4 Cleaning the tubes

If you have changed the type of liquid, or if the machine is not going to be used for a period of time, you can select functions to clean one or all tubes from the bottles to the dosing nozzles.

Procedure

1. Log in to the machine as **Operator**.
2. Tap the **Main menu** icon, and select **Maintenance**.

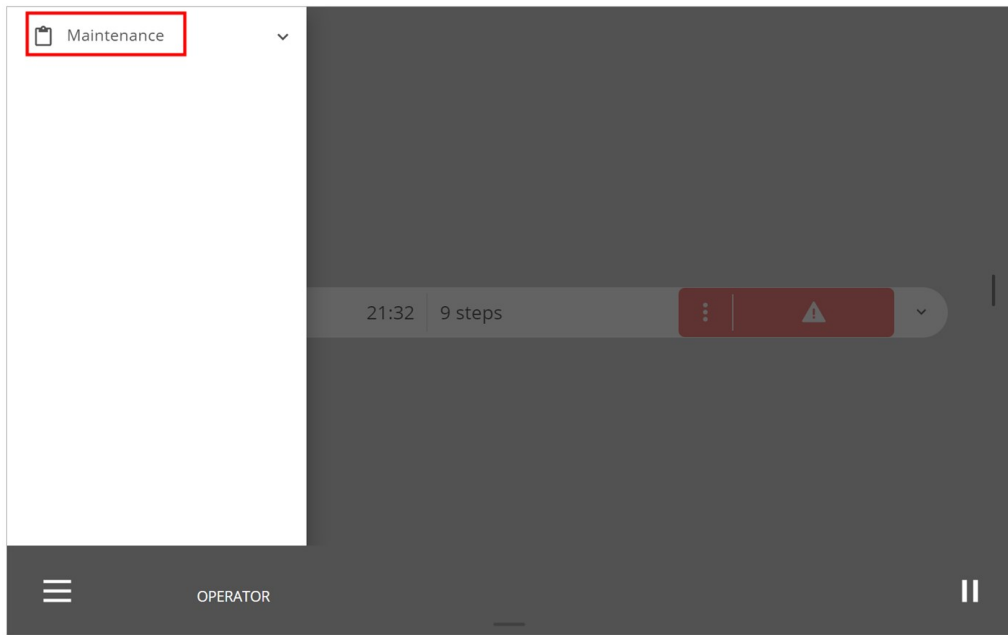

3. Tap Clean tubes.

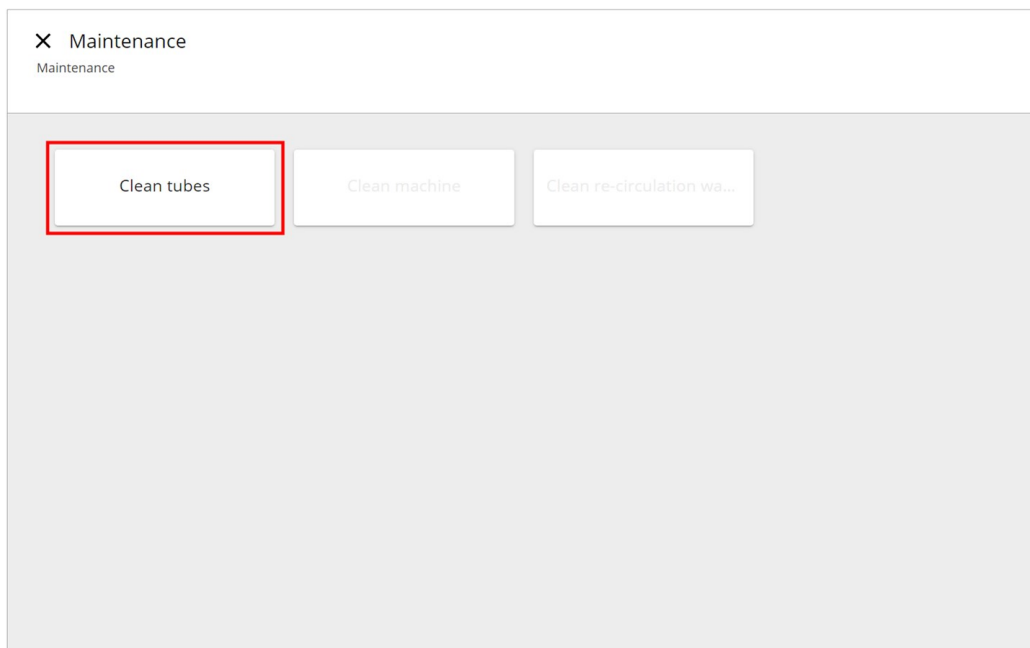

4. Select the tubtles to be cleaned, and place the Easy Connector in inlet on the bottle rack.

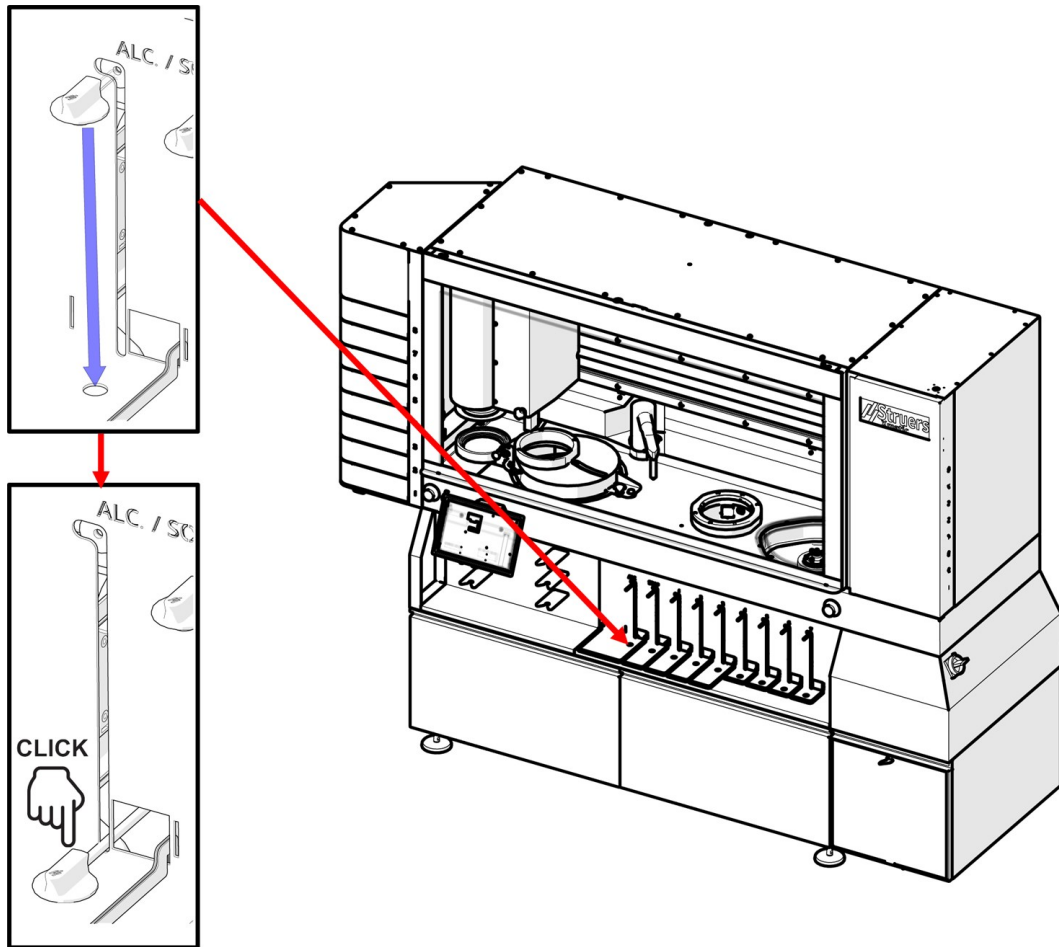

In the **Clean tubes** menu, you can select:

- **Clean tubes**
- **Calibrate tubes and pumps**
- **Fill tube**
- **Empty tube**

5. Select the desired process.

9.2.5 Replacing the stone dresser and the MD dressers

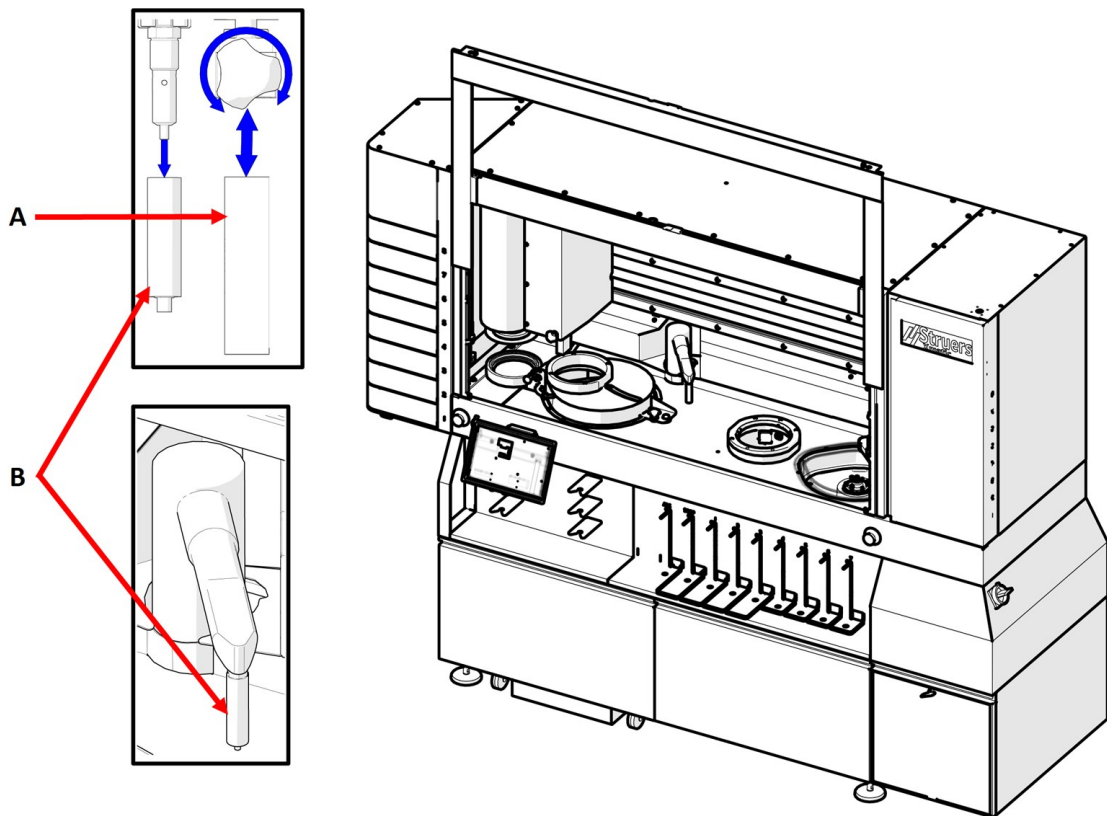

Aluminum oxide stick [A]

1. Untighten the three-lobe knob by rotating it counterclockwise.
2. Mount a new aluminum oxide stick in the holder.
3. Tighten the three-lobe knob again.

Hard tip dresser [B]

4. Dismount the water curtain.
5. Unscrew the old tip. Use a 9 mm Allen key.
6. Mount the new tip. Use a 9 mm Allen key.
7. Remount the water curtain.



Note

The set screw can fall off the arm.

9.2.6 Cleaning the touch screen



Note

Do not use a dry cloth as the surfaces are not scratch resistant.



Note

Do not use acetone, benzol or similar solvents.

1. Clean the touch screen with an LCD cleaning agent.

9.2.7 Cleaning the MD elevator mirrors

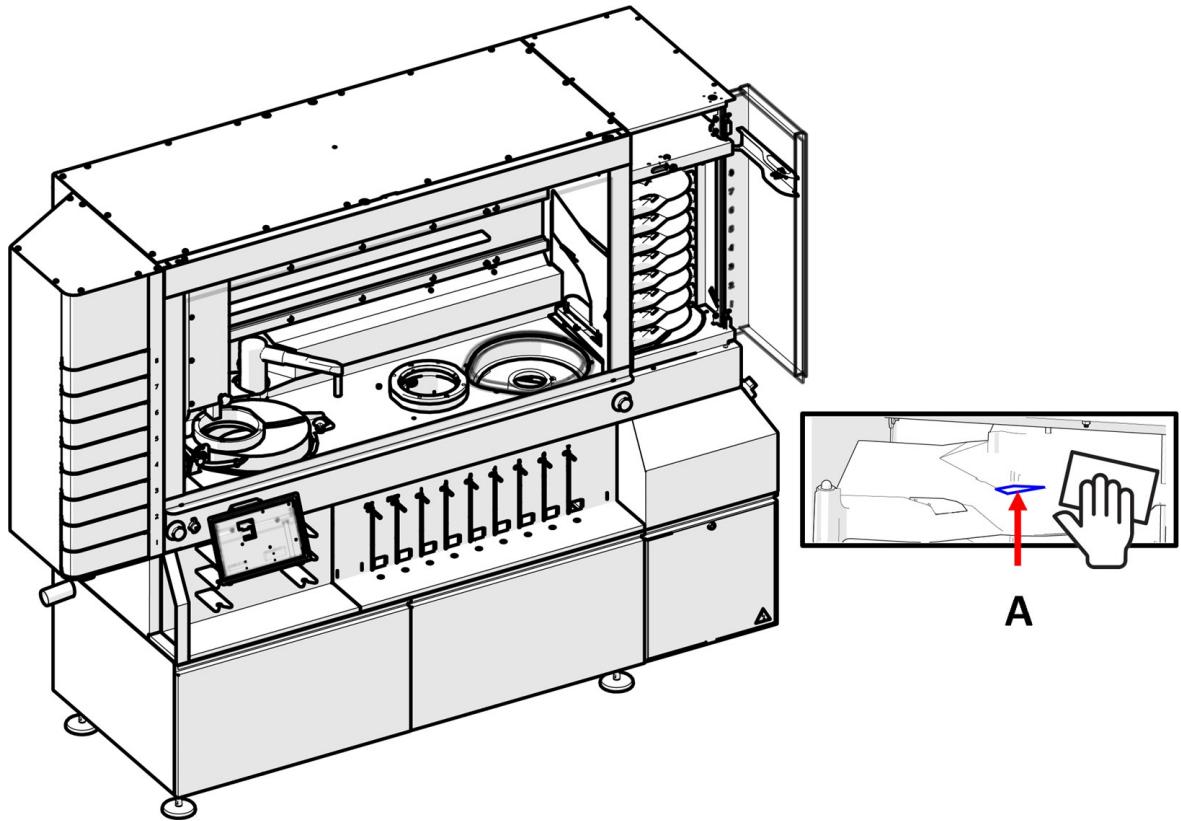

1. Clean the mirrors (A) inside the 9 drawers in the MD surface elevator with a damp cloth.

 **Hint**
If available, you can also use compressed air to clean the mirrors.

 **Note**
Do not use a dry cloth when cleaning the mirrors, as the surface is not scratch-resistant.

9.2.8 Emptying the alcohol separator bottle - (Optional)

 **WARNING**
Always wear protective gloves and safety goggles while you empty the alcohol bottle.

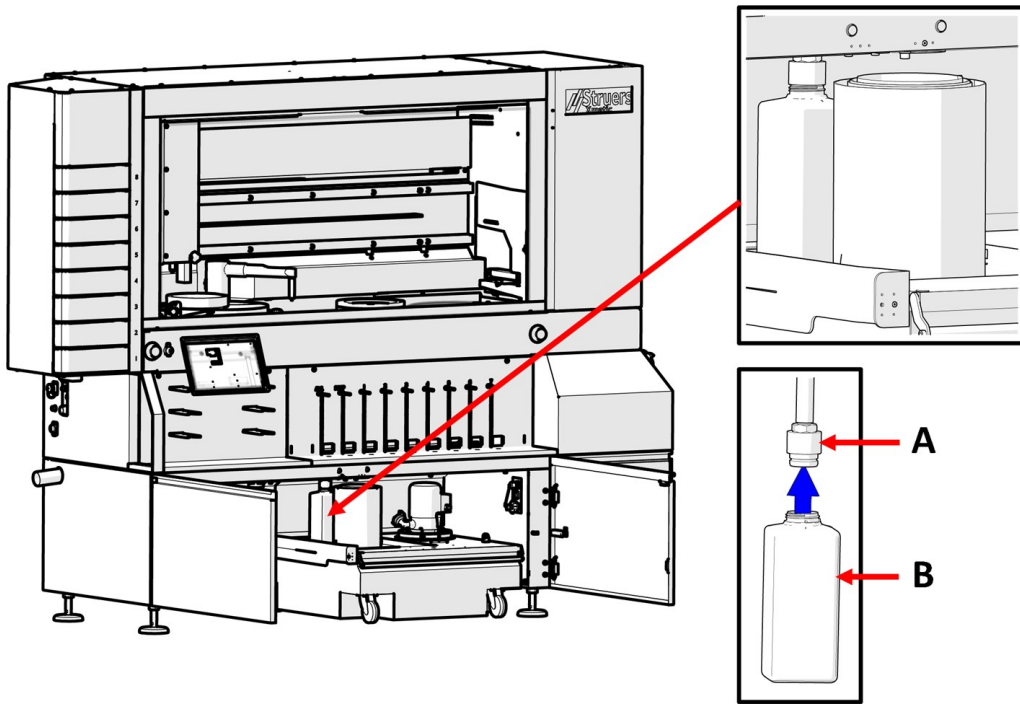

- A Connector for alcohol bottle
- B Alcohol bottle

Procedure

1. Pull the recirculation unit out so you can reach the alcohol bottle.
2. Remove the bottle from the connector for alcohol bottle.
3. Empty the contents of the bottle.
4. Remount the bottle.

9.2.9 MD dressers

The aluminum oxide stone

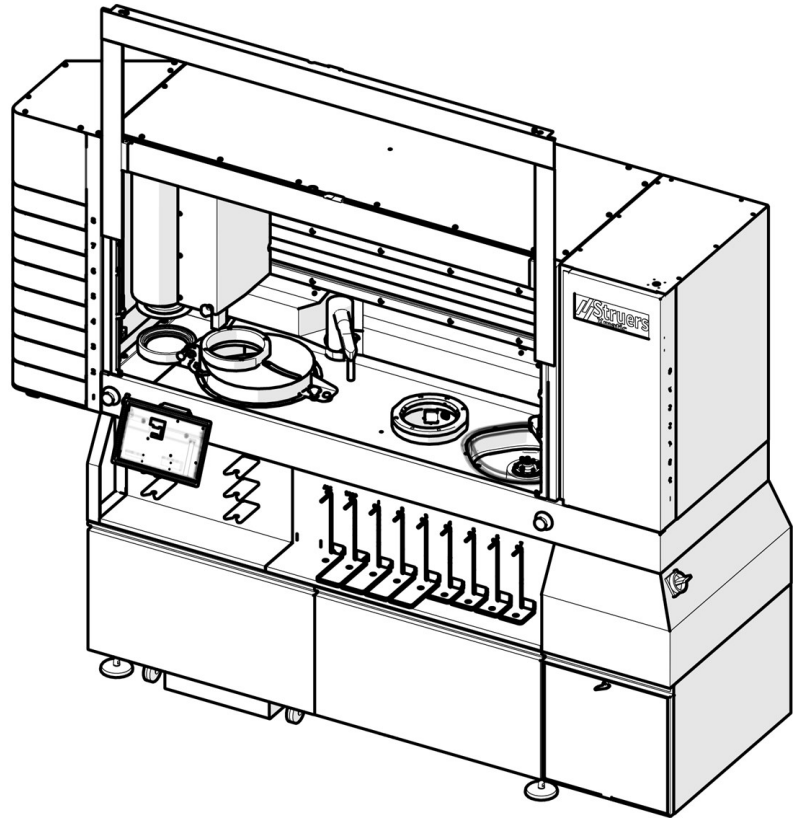
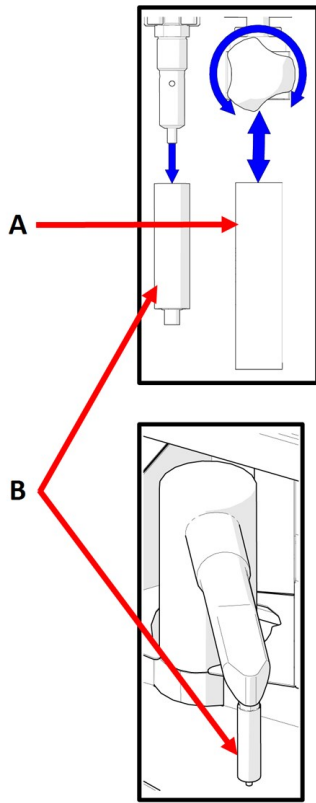

1. Dismount the aluminum oxide stone. (A)
2. Wipe all surfaces carefully and make sure that there is no debris or dirt left.
3. Mount the aluminum oxide stone in the dresser.

Diamond tip dresser

1. Dismount the diamond tip dresser. (B)
2. Wipe all surfaces carefully and make sure that there is no debris or dirt left.
3. Mount the diamond tip in the dresser.

9.3 Daily

Cleaning the machine

9.3.1 MD grinding surfaces

MD grinding surfaces

Check the MD surfaces every day to make sure that they are clean and undamaged:

1. Open the MD elevator door and check each MD grinding surface.
 2. Replace damaged MD grinding surfaces.
 3. Clean the MD grinding surfaces:
 - Carefully brush the surface with a clean, soft nail brush under lukewarm running water.
 - Rinse the surface with distilled water.
 - Dry the surface.
 - Place the surface in the elevator.
 4. Close the MD elevator door. The elevator moves into its parked position.
- See also the user guide for the MD grinding surfaces you are using.

9.4 Weekly

**Note**

Do not use a dry cloth as the surfaces are not scratch resistant.

**Note**

Do not use acetone, benzol or similar solvents.

**Hint**

If needed, use ethanol or isopropanol to remove grease and oil.

9.4.1 The machine

**Note**

Do not use a dry cloth as the surfaces are not scratch resistant.

**Note**

Do not use acetone, benzol or similar solvents.

**Hint**

If needed, use ethanol or isopropanol to remove grease and oil.

The work zone

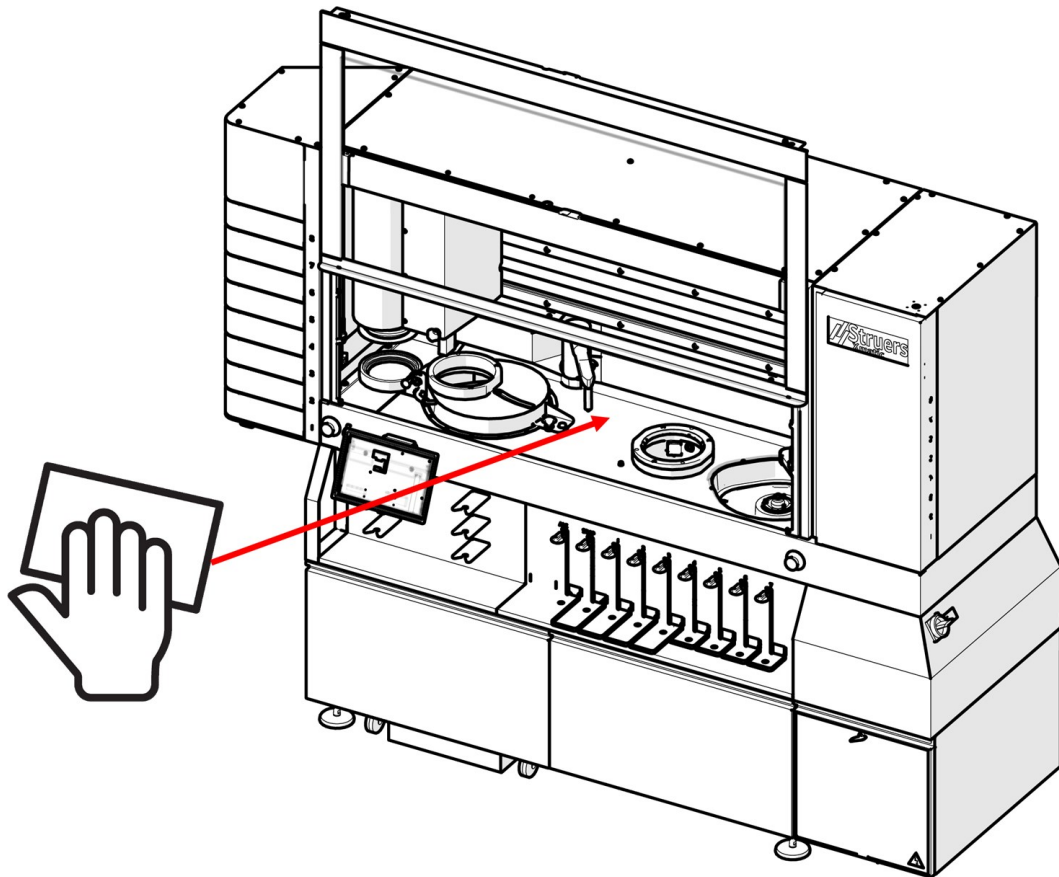

1. Clean all painted surfaces inside the machine with a soft damp cloth and common household detergents.

The specimen mover head and rails

Clean the specimen mover head and rails regularly using a damp cloth. See also: [Overview ► 14](#).

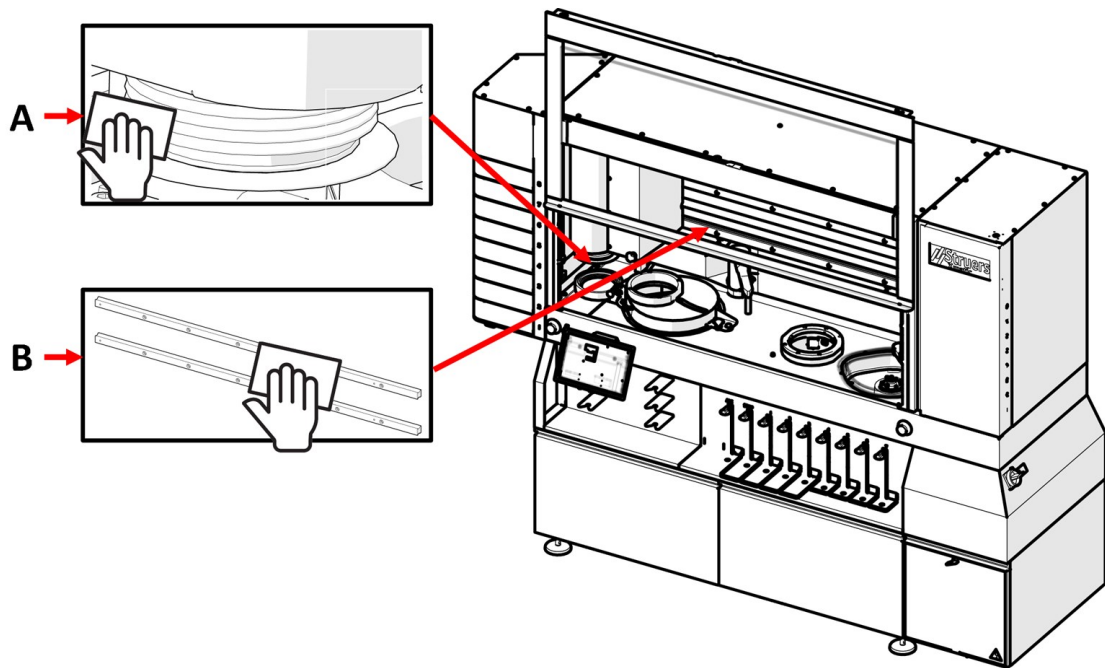

1. Clean the upper and lower part of the specimen mover head (**A**) thoroughly using a damp cloth.
2. Clean any buildup of contaminants on the rails (**B**) inside the work zone using a dry cloth.

**Note**

It is important that you keep the upper and lower surfaces of the specimen mover head clean, otherwise you risk contaminating the specimens.

**Note**

You can use a dry cloth when cleaning the rails inside the work zone, as these are coated with an oil film.

The main safety cover

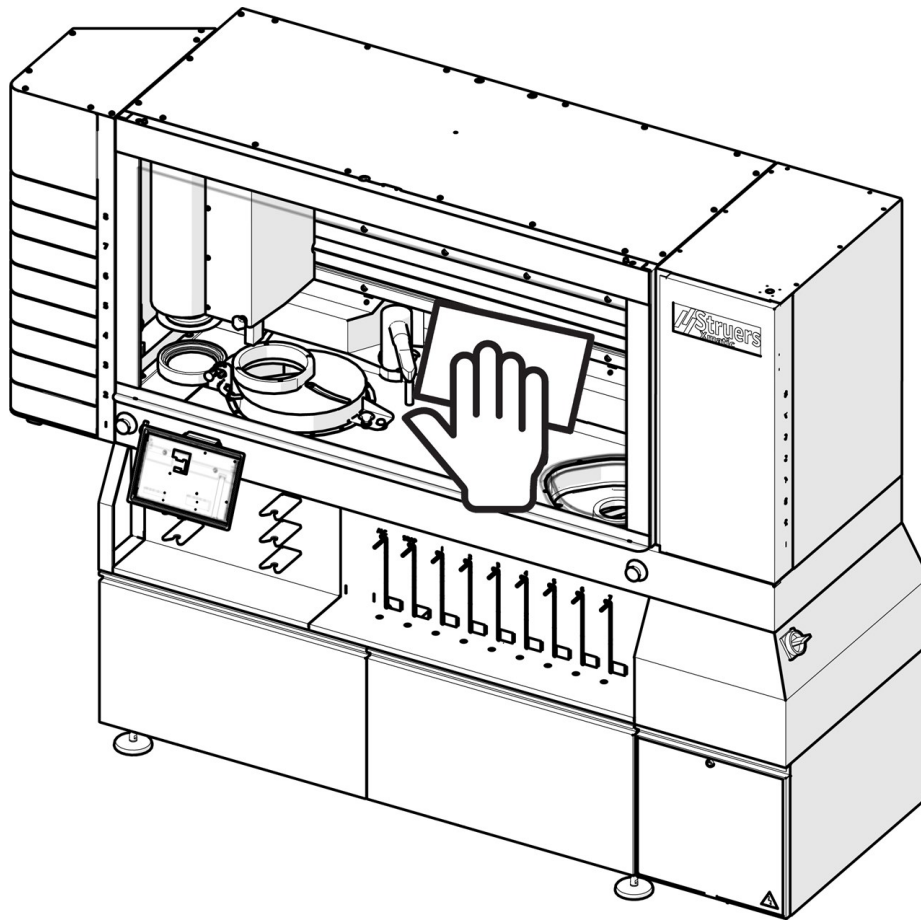

1. Clean the main safety cover regularly using a damp cloth or a regular household window cleaning solution.

Let the window cleaning solution work for a few seconds before wiping it away with a cloth.



Note

Be careful not to apply pressure when cleaning the surface of the main safety cover, as you risk scratching it.

9.4.2 High pressure cleaning station



Note

Do not use a dry cloth as the surfaces are not scratch resistant.



Note

Do not use acetone, benzol or similar solvents.



Hint

If needed, use ethanol or isopropanol to remove grease and oil.

1. Clean the nozzles. See: [Cleaning the nozzles ▶ 73](#)
1. Use a damp cloth to clean the rubber seals.

Cleaning the nozzles

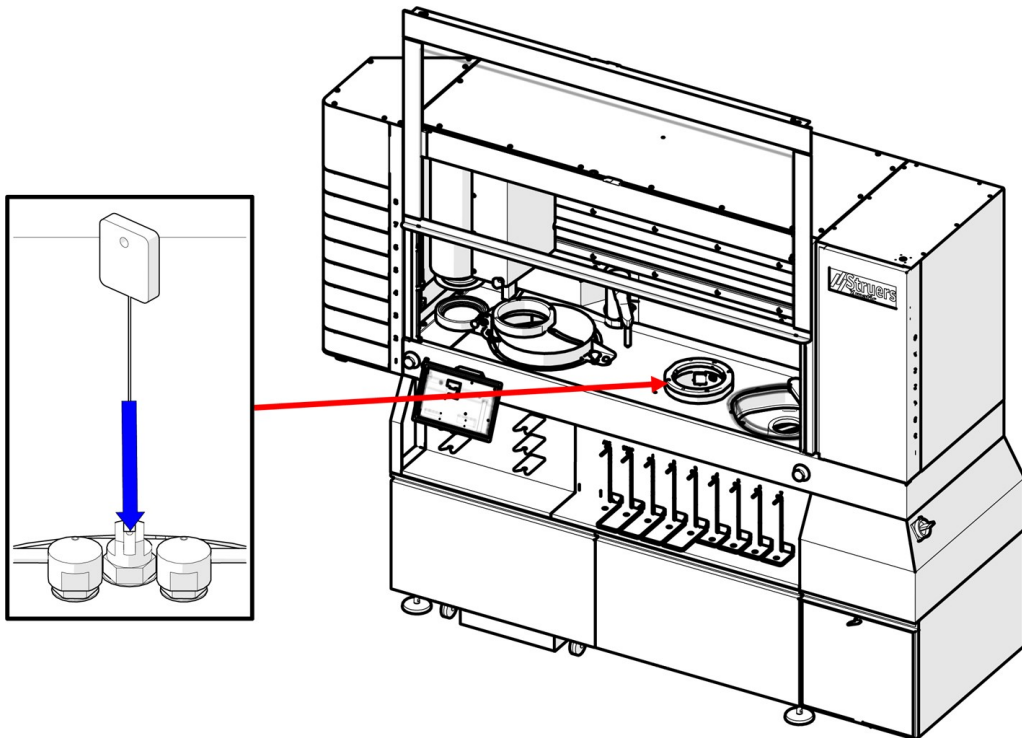

1. Use the nozzle cleaner to clean the nozzles in the high pressure cleaning station.

9.4.3 Ultrasonic cleaning station - (Optional)



Note

Do not use a dry cloth as the surfaces are not scratch resistant.



Note

Do not use acetone, benzol or similar solvents.



Hint

If needed, use ethanol or isopropanol to remove grease and oil.

1. Empty the ultrasonic bath.
2. Use a brush and soap to clean the inner wall of the ultrasonic bath.
3. Empty the ultrasonic bath.
4. Fill the ultrasonic bath.

9.5 Monthly



Note

Do not use a dry cloth as the surfaces are not scratch resistant.



Note

Do not use acetone, benzol or similar solvents.



Hint

If needed, use ethanol or isopropanol to remove grease and oil.

9.5.1 Recirculation unit

1. Clean the recirculation tank and the connected tubes thoroughly.
2. If you use a soap solution to clean the bowl or the recirculation tank, rinse with clean water before filling the recirculation tank.



Note

If the cooling fluid is contaminated by algae or bacteria, replace the cooling fluid immediately.

3. If the recirculation water has been infected with bacteria or algae, clean the tank and tubes with a suitable antibacterial disinfectant.
4. Clean the static filter: Remove it and rinse it with water.

Changing the recirculation water



CAUTION

Avoid skin contact with the cooling fluid additive.



Note

The recirculation water contains additive and grinding residue and you must not dispose of it into the waste water drain.
Recirculation water must be disposed of in compliance with local safety regulations.

Emptying the recirculation tank



CAUTION

Make sure that the main safety cover and the lower doors on the machine are closed before you start emptying the recirculation tank.



CAUTION

The recirculation tank is very heavy when it is full.

5. Disconnect the water hose from the main machine, and place it in the collecting container or drain.
6. Use an external hose to empty the tank.
7. Close the recirculation compartment doors and the main safety cover before starting the recirculation unit.
8. Empty the recirculation unit by starting the equipment and stopping it when the tank is empty. Remove the plastic liner and clean out all water and debris from the tank.
9. Clean the recirculation tank and the connected tubes thoroughly.
10. If the cooling water has been infected with bacteria or algae, clean the tank and tubes with a suitable antibacterial disinfectant.

9.6 Annually

**WARNING**

Do not use the machine with defective safety devices.
Contact Struers Service.

**WARNING**

Safety critical components must be replaced after a maximum lifetime of 20 years.
Contact Struers Service.

**CAUTION**

The safety devices must be tested at least once a year.

**CAUTION**

Testing should always be performed by a qualified technician (electromechanical, electronic, mechanical, pneumatic, etc.).

**CAUTION**

Do not use Xmatic if it is damaged.

**Note**

Replacement of safety critical components must only be performed by a Struers engineer or a qualified technician (electromechanical, electronic, mechanical, pneumatic, etc.).
Safety critical components must only be replaced by components with at least the same safety level.
Contact Struers Service.

9.6.1 Main safety cover

Inspecting the main safety cover



Hint

If the machine is used for more than one 7-hour shift per day, carry out inspection more often.

1. Visually inspect the main safety cover for signs of wear or damage such as cracks, dents, or damage.

Replacing the main safety cover



CAUTION

The main safety cover must be replaced by a Struers technician.



Note

The main safety cover must be replaced immediately if it has been weakened by collision with projectile objects or if there are visible signs of deterioration or damage.

9.6.2 Testing safety devices

The safety devices must be tested at least once a year.



WARNING

Do not use the machine with defective safety devices. Contact Struers Service.



Note

Testing should always be performed by a qualified technician (electromechanical, electronic, mechanical, pneumatic, etc.).

Emergency stop

1. Start a polishing process. Wait until the specimen is being grinded/polished.
2. Press one of the Emergency stops. See also: [Overview ► 14](#).
3. All movements should stop and a pop-up message should be shown in the display.
4. If the machine does not stop moving, select **Stop** on the display.
5. Contact Struers Service.

Vertical conveyor

1. Make sure that at least one of the drawers on the vertical conveyor is empty.
2. Start a preparation process
3. Try to open the empty drawer completely while the machine is picking up and moving the specimen holder.
4. If the machine does not stop moving, select **Stop** on the display.

5. Contact Struers Service.

Main safety cover

Testing the main safety cover interlock

1. Open the main safety cover.
2. Start a preparation process.
3. If the machine starts the preparation process, press one of the Emergency stops. See also: [Overview ► 14](#).
4. Contact Struers Service.

Testing the main safety cover locking function

1. Start a preparation process.
2. Try to open the main safety cover.
3. If you can open the main safety cover, press one of the Emergency stops. See also: [Overview ► 14](#).
4. Contact Struers Service.

MD elevator

1. Open the MD elevator door.
2. Close the door and listen to the movements that occur inside the MD elevator.
3. Try to open the MD elevator door.
4. If you can open the MD elevator door, press one of the Emergency stops. See also: [Overview ► 14](#).
5. Contact Struers Service.

Grinding stone cover

1. Open the main safety cover.
2. Loosen the three-lobe knob for the grinding stone cover until you can lift the cover. See also: [Mounting the grinding stone or diamond grinding disc ► 36](#).
3. Close the cover again, but do not tighten the three-lobe knob.
4. Close the main safety cover.
5. Try to start a grinding process.
6. If the pick-up arm starts picking up a specimen holder, press one of the Emergency stops. See also: [Overview ► 14](#).
7. Contact Struers Service.

Recirculation unit compartment

1. Start a grinding process.
2. Open the recirculation unit compartment.
3. The recirculation unit pump should stop immediately. If this is not the case, press one of the Emergency stops. See also: [Overview ► 14](#).

4. Contact Struers Service.

9.7 Spare parts

Technical questions and spare parts

If you have technical questions or when you order spare parts, state the serial number. The serial number is stated on the type plate of the unit.

For further information, or to check the availability of spare parts, contact Struers Service. Contact information is available on [Struers.com](https://www.struers.com).

9.8 Service and repair

Struers recommends that a regular service check be carried out yearly or after every 1500 hours of use.

When the machine is started up, the display shows information about total operation time and the machines service information.

After 1000 hours of operation time, the display will show a message reminding the user that a service check should be scheduled.



Note

Service must only be performed by a Struers engineer or a qualified technician (electromechanical, electronic, mechanical, pneumatic, etc.). Contact Struers Service.

Service check

Struers offers a range of comprehensive maintenance plans to suit the requirements of our customers. This range of services is called ServiceGuard.

The maintenance plans include equipment inspection, replacement of wear parts, adjustments/calibration for optimal operation, and a final functional test.

9.9 Disposal



Equipment marked with a WEEE symbol contains electrical and electronic components and must not be disposed of as general waste.

Contact your local authorities for information on the correct method of disposal in accordance with national legislation.



For disposal of consumables and recirculation fluid, follow local regulations.

9.9.1 Environmental considerations



WARNING

In case of fire, alert bystanders, the fire brigade and cut power. Use a powder fire extinguisher. Do not use water.

**Note**

Swarf must be disposed of according to the current safety regulations for handling and disposal of swarf/ additive in the recirculation water.

**Note**

The recirculation water contains additive and swarf and may NOT be disposed of into a main drain.
Cooling fluid must be disposed of in compliance with local safety regulations.

10 Troubleshooting - Xmatic

Error	Cause	Action
Continuous, irregular wear on a grinding/polishing surface.	Coupling on the specimen holder or the specimen mover head is worn.	Replace the coupling. Contact Struers Service.

10.1 Accessing the work zone in case of power failure

1. Make sure that the main switch is in the off position. See: [Overview](#) ► 14.
2. Use the triangular key supplied with the machine to unblock the main safety cover and the MD elevator. See: [Checking the packing list](#) ► 22.

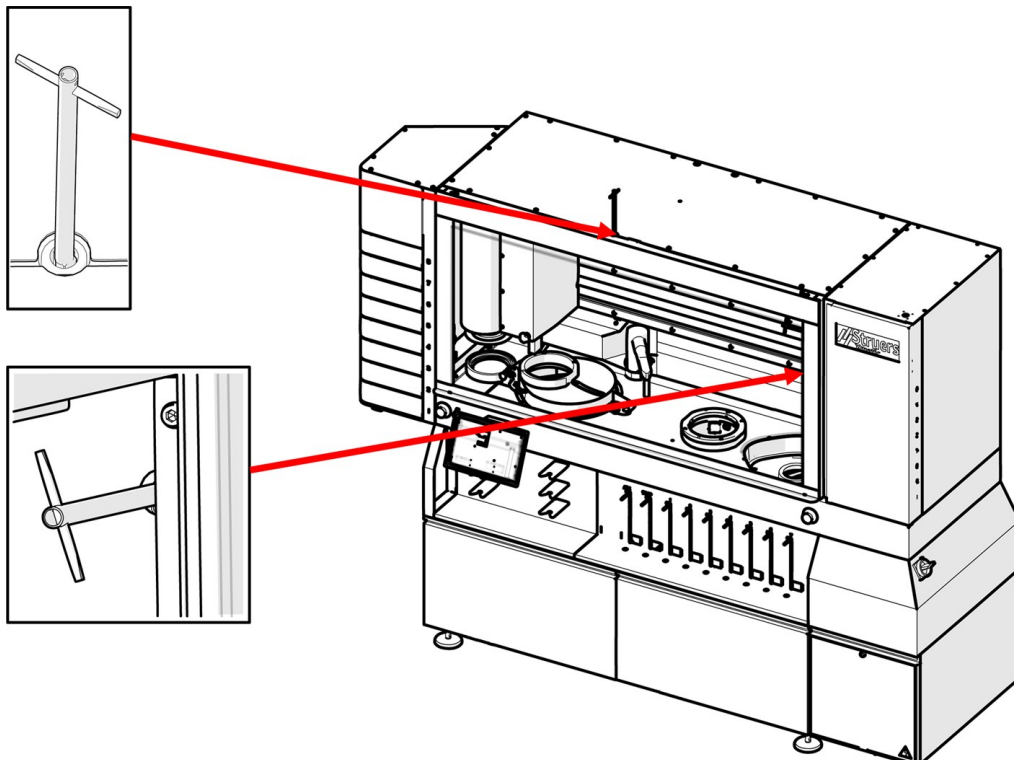

3. Turn the key clockwise to open the main safety cover and the MD elevator.

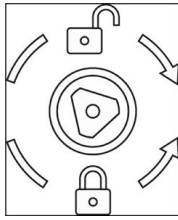

11 Technical data

11.1 Technical data

Capacity	Diameter	250 mm MD disc: 4 x 40 mm, 300 mm disc: 4 x 50 mm
High removal plane grinding station	Diameter	270 mm
	Speed	1450 rpm
	Material removal sensor (built-in)	0.05 mm - 10 mm (0.002-0.4")
	Rotational direction	Clockwise
	Motor power	2.2 kW
	Continuous (s1)Continuous (S1)	
	Max. (s3)Max. (S3)	
MD grinding and polishing station	Diameter	250 mm or 300 mm
	Speed	50 - 600 rpm
	Material removal sensor (built-in)	0.05 mm - 5 mm (0.002 - 0.2")
	Rotational direction	Counter-clockwise
	Motor power	1.5 k W
	Continuous (s1)Continuous (S1)	3.21 A
	Max. (s3)Max. (S3)	5.1 A

TECHNICAL DATA

Xmatic

Mover head	Specimen holder	Applicable only with RFID-tag holders
	Weight	4 kg (8.8 lbs) incl. specimens
	Max. protrusion of specimen under holder	6 mm
	Specimen holder - Diameter	140 mm (MD disc 250 mm) or 160 mm (MD disc 300 mm)
	Force	50 - 500 N
	Force accuracy	+/-10% up to 100N, +/-10N on higher values
	Speed	Process 150 - 600 rpm Drying 1400 rpm
	Rotational direction	Counter-clockwise, Clockwise
	Dressing of MD surfaces	Automatic (diamond tip/aluminum oxide stick)
	Motor	1.1 kW
	Torque	7.3 Nm @ 150 rpm
	Vertical conveyor	Number of specimen holders
MD elevator	Number of MD surfaces	8
Cleaning station	Ultrasonic (option)	70 W
	High pressure including alcohol and soap	40 bar
Doser module	Automatic dosing	7 pumps for OP or DP suspension
		1 pump for alcohol for cleaning station
		1 pump for soap for cleaning station
		Automatic cleaning (for pump positions only)
Recirculation cooling system	High removal plane grinding station	Yes.
	Grinding and polishing MD station	Option
Software and electronics	Touchscreen	Capacitive
	Display	LCD, 12.1" (1280 x 800)
Safety standards	See the Declaration of Conformity	

TECHNICAL DATA

Xmatic

Operating environment	Surrounding temperature	
	During operation	5 - 40°C (41 - 104°F)
	During transport	-25°C - 55°C (transport) -25°C - 70°C (max. 24 hours during transport)
	Humidity	35 - 85 % RH non-condensing
Water supply (tap water)	Pressure	1 - 9.9 bar (14.5 - 143 psi)
	Flow	Min. 10 l/m (2.6 gmp)
Compressed air supply	Pressure	6 - 9.9 bar (87 - 143 psi)
	Flow	Min. 200 l/m (53 gpm)
	Recommended quality	Class-3, as specified in ISO 8573-1
Waste water outlet	Diameter	50 mm (1.97")
	Outlet height	50 cm (19.7")above the floor
	Max. distance to drain	600 cm
	Slope	Min. 8%
Power supply	Voltage/frequency	220 V/430 V +/-15% (50/60Hz)
	Power inlet	15 A
	Power	2.2 KW
	Nominal load	1.5 KW
	Idle	500 W
	Current	
	Nominal	4 A
	Max.	15 A

TECHNICAL DATA

Xmatic

Safety Circuit Categories/Performance Level	SF-1	PL c, Category 1 Stop category 0
	SF-2	PL d, Category 3 Stop category 0
	SF-3	PL d, Category 3 Stop category 0
	SF-4	PL d, Category 3 Stop category 0
	SF-5	PL d, Category 1 Stop category 0
	SF-5A	PL c, Category 3 Stop category 0
	SF-6	PL a, Category b Stop category 0
	SF-7	PL c, Category 3 Stop category 0
	SF-8	PL c, Category 1 Stop category 0
	SF-9	PL d, Category 3 Stop category 0
	SF-10	PL b, Category 1 Stop category 0
SF-11	PL b, Category 1 Stop category 0	
Exhaust	Diameter	50 mm (2")
	Recommended capacity	150 m ³ /h (5297 ft ³ /h)
Noise level	A-weighted sound emission pressure level at workstations	LpA = 65 dB(A) (measured value). Uncertainty K = 4 dB
Noise level	Equivalent ultrasound sound pressure level (equivalent level of ultrasound)	Lteq, T=95.2 dB (measured value). Uncertainty K = 2 dB

TECHNICAL DATA

Xmatic

Noise level	<p>The figures quoted are emission levels and are not necessarily safe working levels. While there is a correlation between the emission and exposure levels, this cannot be used reliably to determine whether or not further precautions are required. Factors that influence the actual level of exposure of the workforce include characteristics of the work room, the other sources of noise, etc., i.e. the number of machines and other adjacent processes. Also, the permissible exposure level can vary from country to country. This information, however, will enable the user of the machine to make a better evaluation of the hazard and risk.</p>	
Vibration level	Declared vibration emission	N/A
Dimensions and weight	Width	242.5 cm (95.5")
	Depth	75.0 cm (29.5")
	Height	189.0 cm (74.4")
	Height (with open cover)	244.0 cm (96.0")
	Weight	960 kg (2116.4 lbs)
REACH	<p>For information about REACH, contact your local Struers office.</p>	

11.2 Safety Related Parts of the Control System (SRP/CS)



WARNING

The machine and its parts have been designed to operate 16 hours daily/220 days annually. If used as indicated, the safety critical components must be replaced after a maximum lifetime of 20 years.

If you use the machine for longer periods of time than indicated, the safety critical components must be replaced sooner.

Contact Struers Service.



Note

SRP/CS (safety-related parts of a control system) are parts that have an influence on safe operation of the machine.



Note

Replacement of safety critical components must only be performed by a Struers engineer or a qualified technician (electromechanical, electronic, mechanical, pneumatic, etc.).

Safety critical components must only be replaced by components with at least the same safety level.

Contact Struers Service.

Parts

Safety related part	Manufacturer/Manufacturer description	Manufacturer catalog no.	Electrical ref.	Struers catalog no.	ID
Emergency stop	Omron	A22NE-M-N	S02	2SA41700	SF-1
Abrasive guard interlock, plane grinding guard interlock	Sick Safety sensors	IME2S12-04B4DW2	B37	2SS00812	SF-2
Stone limited speed, plane grinding station	Schneider Electric Inverter	ATV320U22N4B	Q01	2PU23422	SF-3

Safety related part	Manufacturer/Manufacturer description	Manufacturer catalog no.	Electrical ref.	Struers catalog no.	ID
Specimen holder mover limited speed, (specimen mover head)	Schneider Electric Inverter	ATV320U15N4B	Q02	2PU23415	SF-4
Main safety cover interlock, hazardous movements	Sick Inductive sensor Schmersal Safety lock	IME2S12-04B4DW2 AZM 161SK-1212RKED-024	B44	2SS00812	SF-5
			F31	2SS00120	
Main safety cover interlock, water and ethanol	Sick Inductive sensor Schmersal Safety lock	IME2S12-04B4DW2 AZM 161SK-1212RKED-024	B44	2SS00812	SF-5A
			F31	2SS00120	
Main safety cover locking device	Schmersal Safety lock	AZM 161SK-1212RKED-024	F31	2SS00120	SF-6
MD elevator door interlock	Sick Inductive sensor	IME2S12-04B4DW2	B43	2SS00812	SF-7
MD elevator door locking device	Schmersal Safety lock	AZM 161SK-1212K-024	F30	2SS00124	SF-8
Vertical conveyor interlock	Safety light sender/receiver SH feeder	L41S-11MA1A L41E-11MA1A	B40	2HQ00110	SF-9
			B41	2HQ00120	
Recirculation doors interlocks	Sick Inductive sensor	IME2S12-04B4DW2	B38 B39	2SS00812	SF-10
Exhaust supervision system			B05		SF-11

11.3 Diagrams

If you wish to view specific information in detail, see the online version of this manual.

11.3.1 Diagrams - Xmatic

Title	No.
Pneumatic circuit diagram	16891001 C ▶ 89
Water diagram	16891000 C ▶ 90
Block diagram	19543050 A ▶ 91

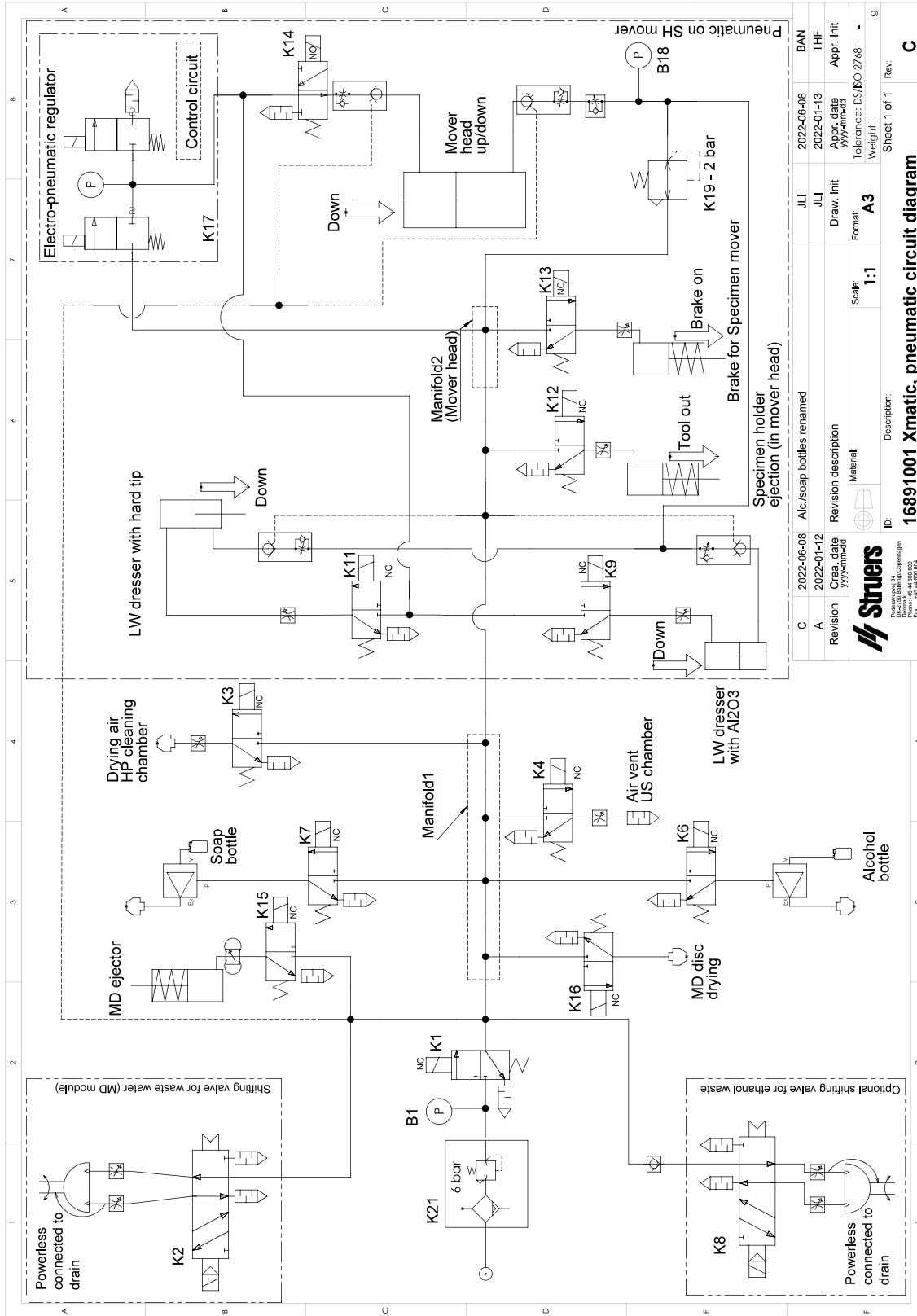

C	2022-06-08	Alc.isop bottles renamed	JLI	2022-06-08	BAN
A	2022-01-12		JLI	2022-01-13	THF
Revision	Cre. date	Revision description	Draw. Init	Appr. date	Appr. Init
	yyyymmdd			yyyymmdd	
Material			Scale:	Tolerance: DS/ISO 2768-	
ID:			Format:	Weight:	
Description:			A3		
16891001 Xmatic, pneumatic circuit diagram			1:1		
			Sheet 1 of 1	Rev:	C



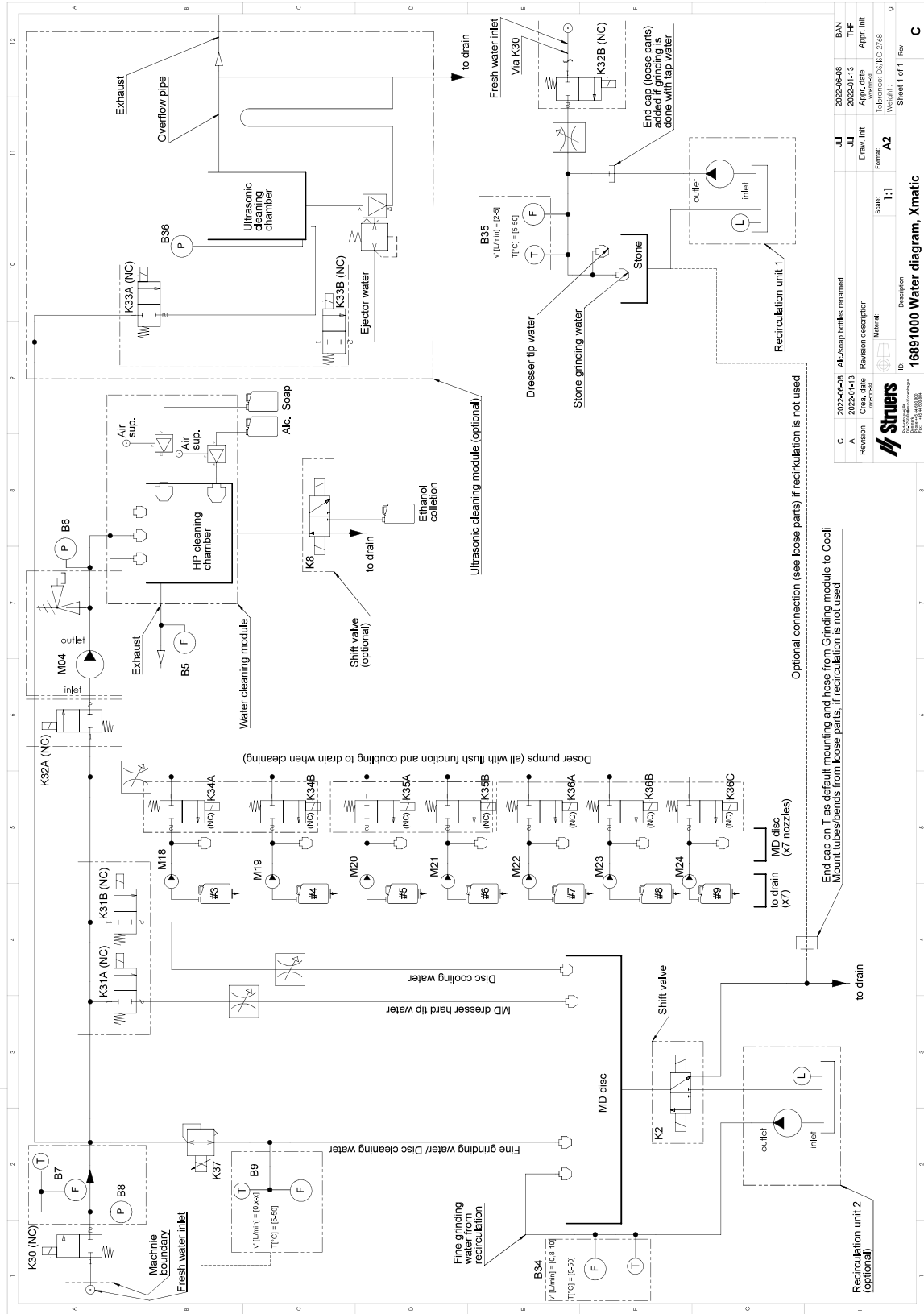

C	2022-06-08	AL-Soap bottles renamed	JUL	2022-06-08	BAN
A	2022-01-13	Revision description	JUL	2022-01-13	THF
Revision	Draw. date	Revision description	Draw. date	Appr. date	Appr. init
Material		Scale	Tolerance: ISO/NO 2768		
ID		Weight	Sheet 1 of 1 Rev.		
Description		1:1	A2		
16891000 Water diagram, Xmatic					



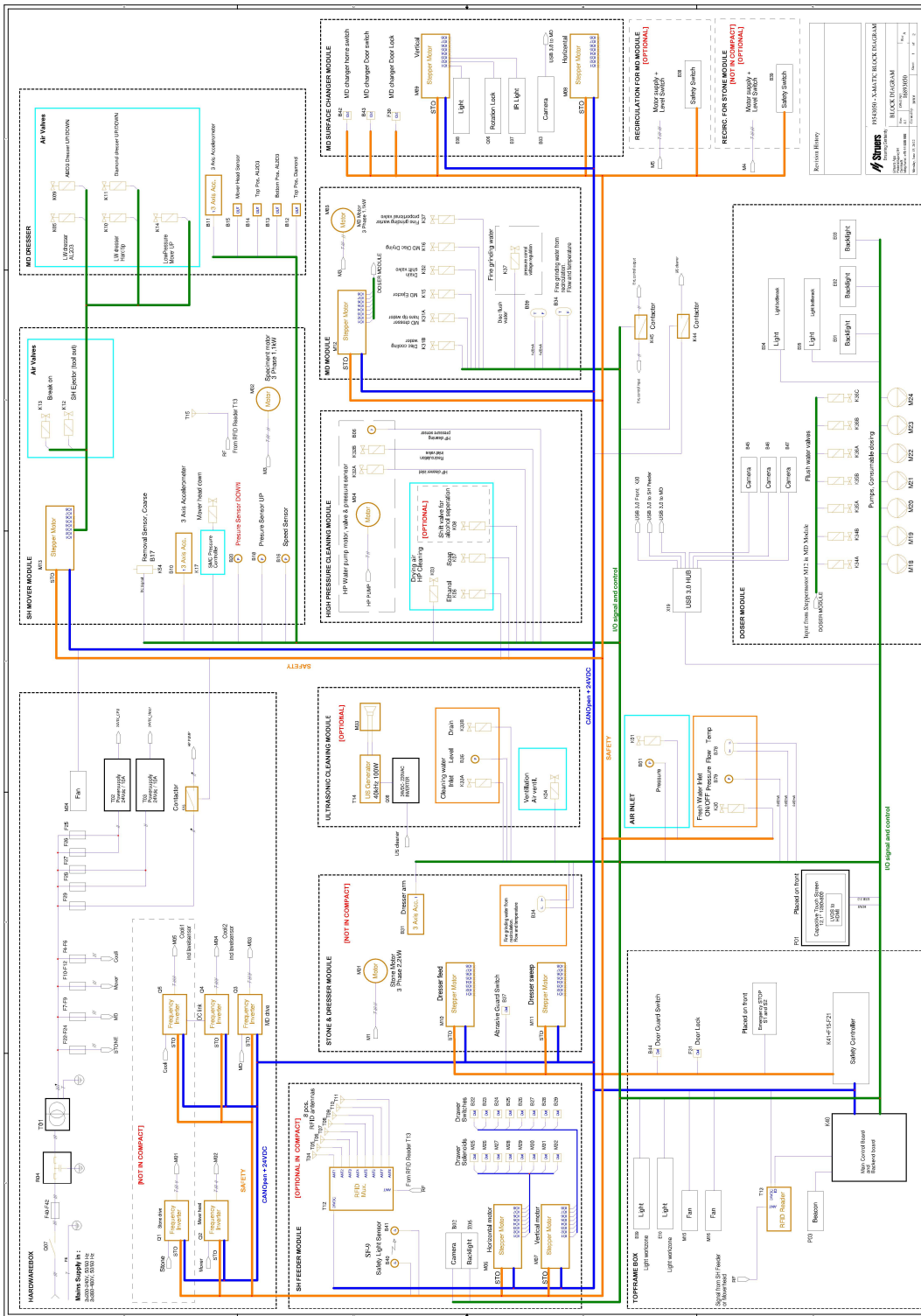

11.4 Legal and regulatory information

FCC notice

This equipment has been tested and found to comply with the limits for a Class B digital device, pursuant to part 15 of the FCC Rules. These limits are designed to provide reasonable protection against harmful interference in a residential installation. This equipment generates, uses and can radiate radio frequency energy and, if not installed and used in accordance with the instructions, may cause harmful interference to radio communications. However, there is no guarantee that interference will not occur in a particular installation. If this equipment does cause harmful interference to radio or television reception, which can be determined by turning the equipment off and on, the user is encouraged to try to correct the interference by one or more of the following measures:

- Reorient or relocate the receiving antenna.
- Increase the separation between the equipment and receiver.
- Connect the equipment into an outlet on a circuit different from that to which the receiver is connected.

12 Manufacturer

Struers ApS
Pederstrupvej 84
DK-2750 Ballerup, Denmark
Telephone: +45 44 600 800
Fax: +45 44 600 801
www.struers.com

Responsibility of the manufacturer

The following restrictions should be observed, as violation of the restrictions may cause cancellation of Struers legal obligations.

The manufacturer assumes no responsibility for errors in the text and/or illustrations in this manual. The information in this manual is subject to change without notice. The manual may mention accessories or parts not included in the supplied version of the equipment.

The manufacturer is to be considered responsible for effects on safety, reliability, and performance of the equipment only if the equipment is used, serviced, and maintained in accordance with the instructions for use.

Declaration of Conformity

Manufacturer	Struers ApS • Pederstrupvej 84 • DK-2750 Ballerup • Denmark
Name	Xmatic
Model	N/A
Function	Grinding/Polishing equipment abrasive stone/disk
Type	06896229, 06896246, 06896129, 06896146
Serial no.	



Module H, according to global approach

EU

We declare that the product mentioned is in conformity with the following legislation, directives and standards:

2006/42/EC	EN ISO 12100:2010, EN ISO 13849-1:2015, EN ISO 13849-2:2012, EN ISO 13850:2015, EN 14118, EN ISO 16089:2015, EN ISO 20607:2019, EN 60204-1:2018, EN 60204-1-2018/Corr.:2020,
2009/125/EC	
2011/65/EU	EN 63000:2018
2014/30/EU	EN 61000-3-3:2013, EN 61000-6-2:2005, EN 61000-6-2:2005/Corr.:2005, EN 61000-6-4:2007, EN 61000-6-4:2007/A1:2011,
2014/53/EU	
1907/2006/EU	
Additional standards	NFPA 70, NFPA 79, FCC 47 CFR Part 15 Subpart B

Authorized to compile technical file/
Authorized signatory

VP Business Development

Enter release date:

Date: [Release date]

